

Tool Holder Program

ALX 1500-2500 MC/Y/SY
NLX 2500 (static turret only)
NLX/NL 1500-4000 MC/Y/SMC/SY
NLX/NL 1500-2500 (20 ST)
NLX 4000 (High Torque Milling)
NLX 6000, NZX 4000
NZX 1500-2000 (16 ST)
NZX 2500 (BMT60)
NZX 2500 (turret 2 = BMT40)
NZX 6000
NTX 1000-3000 2nd Generation (BMT40)
NTX 2000-3000 2nd Generation (BMT60)
NT 4200-5400

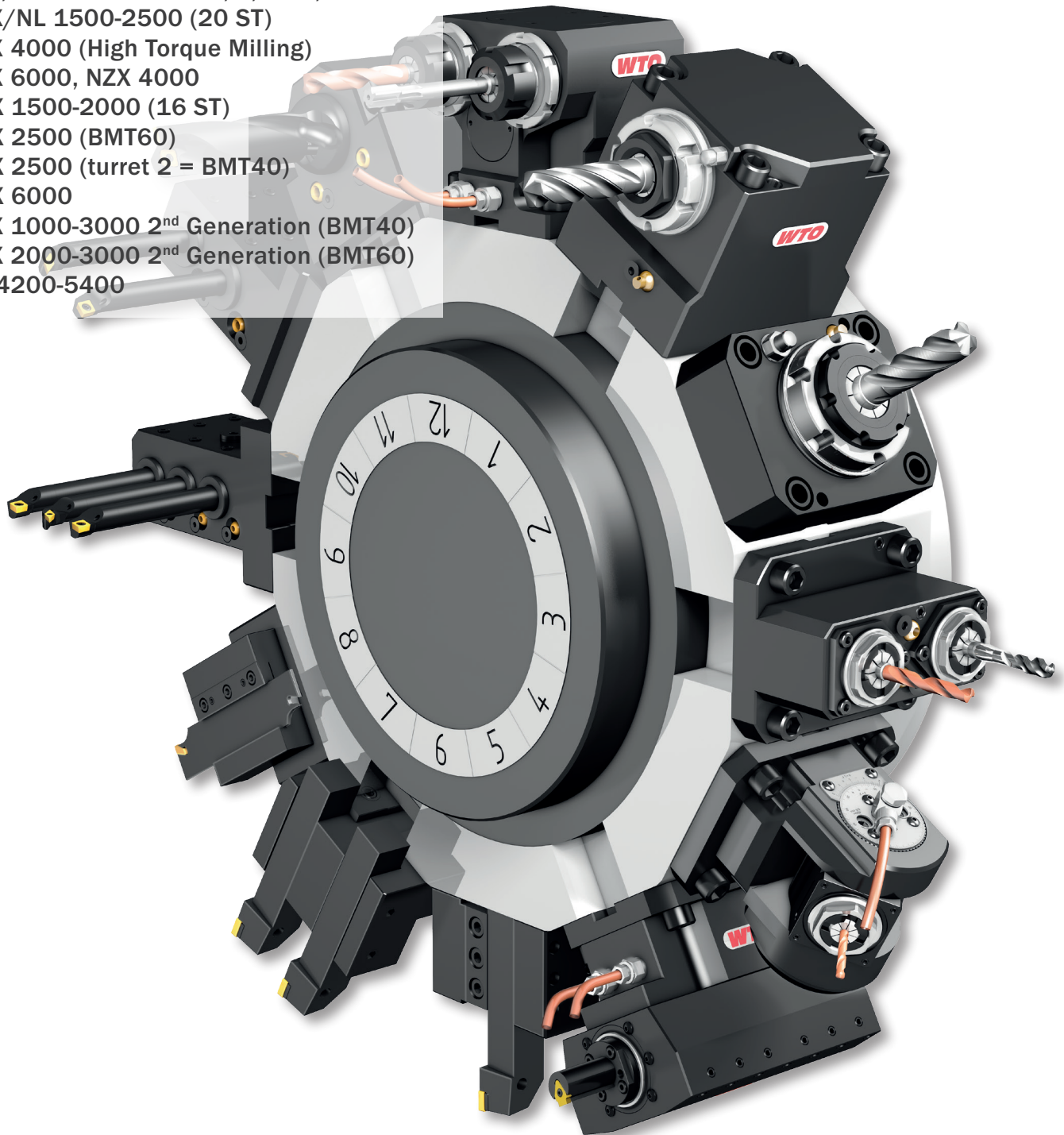

DMG MORI



QuickFlex®

The new quick change system for high performance and precision.

Minimal investment, maximal expandability.

Designed
for



ALX 1500-2500 MC/Y/SY	Page	4 - 8
NLX 2500 (static turret only)	Page	9 - 9
NLX/NL 1500-4000 MC/Y/SMC/SY	Page	10 - 16
NLX/NL 1500-2500 (20 ST)	Page	17 - 21
NLX 4000 (High Torque Milling)	Page	22 - 24
NLX 6000, NZX 4000	Page	25 - 26
NZX 1500-2000 (16 ST)	Page	27 - 31
NZX 2500 (BMT60)	Page	32 - 36
NZX 2500 (turret 2 = BMT40)	Page	37 - 40
NZX 6000	Page	41 - 42
NTX 1000-3000 2nd Generation (BMT40)	Page	43 - 47
NTX 2000-3000 2nd Generation (BMT60)	Page	48 - 51
NT 4200-5400	Page	52 - 55
Reduction sleeves	Page	56 - 59
Collets	Page	60 - 62

EC = External coolant supply
HP-IC = High pressure internal coolant supply through cutting tool
IC 80 bar = Internal and external coolant supply
 Max. coolant pressure = 80 bar
IC 30 bar = Internal and external coolant supply
 Max. coolant pressure = 30 bar
 Only use filtered coolant fluid (max. particle size = 50 µm)
 Do not run without coolant
 Do not use for machining abrasive materials such as cast iron, etc.

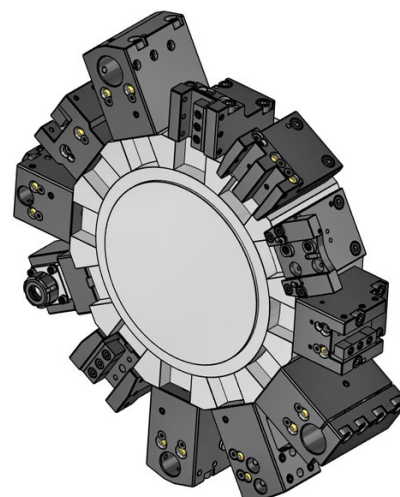
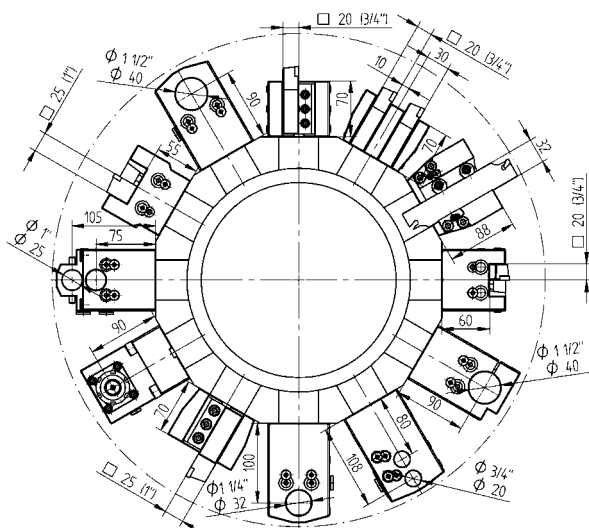

Static Toolholders - Standard Program

Static Toolholders - Standard Program

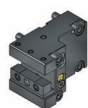

OD cutting holder, short

- 20** 48-T00224
T00224
- 25** 48-T00267
T00267
- 3/4"** 48-T00234
T00234
- 1"** 48-T00272
T00272



OD cutting holder, short, HP-IC

- 20** 48-T00224-HP IC 80 bar
T00224
- 25** 48-T00267-HP IC 80 bar
T00267
- 3/4"** 48-T00234-HP IC 80 bar
T00234
- 1"** 48-T00272-HP IC 80 bar
T00272

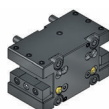

OD cutting holder, both sides, short

- 20** 48-T00228
T00228
- 25** 48-86523
- 3/4"** 48-T00250
T00250
- 1"** 48-86524

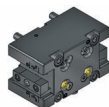

OD cutting holder, both sides, short, HP-IC

- 20** 48-T00228-HP IC 80 bar
T00228
- 25** 48-86523-HP IC 80 bar
- 3/4"** 48-T00250-HP IC 80 bar
T00250
- 1"** 48-86524-HP IC 80 bar



Face cutting holder

- 25** 48-T03024
T03024
- 3/4"** 48-T03018
T03018
- 1"** 48-T03025
T03025



Face cutting holder, HP-IC

- 20** 48-T03017-HP IC 80 bar
T03017
- 3/4"** 48-T03018-HP IC 80 bar
T03018



Cut-off holder, right hand

- 20** 48-T00251
T00251
- 25** 48-T00268
T00268, T00356
- 3/4"** 48-T00252
T00252
- 1"** 48-T00359
T00359, T00357



Boring bar holder

- Ø 32** 48-T10115
T10115
- Ø 1 1/4"** 48-T10119
T10119



Combination toolholder

- Ø 32** 48-T13132 IC 80 bar
T13132
- Ø 40** 48-77999 IC 80 bar
- Ø 1 1/4"** 48-T13135 IC 80 bar
T13135
- Ø 1 1/2"** 48-80016 IC 80 bar



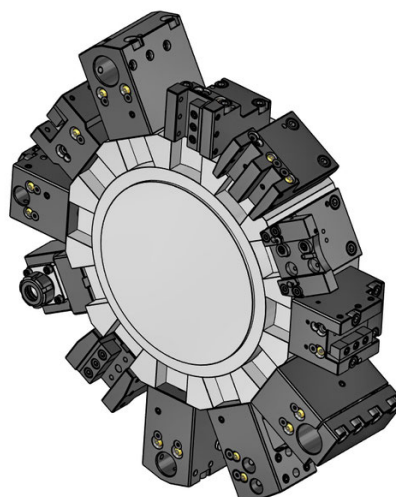
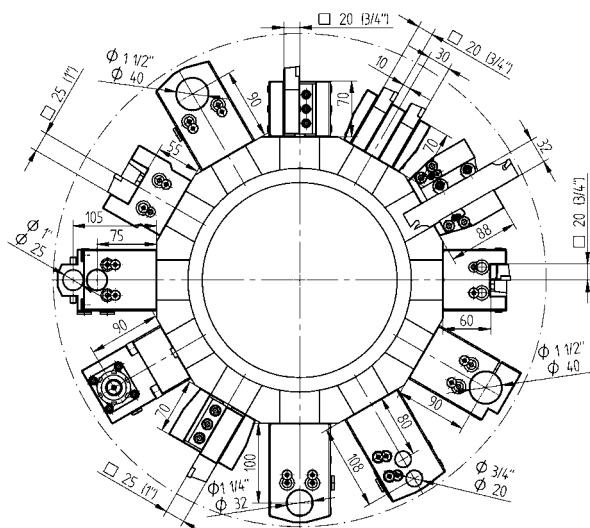

Boring bar holder, both sides

- Ø 25** 48-T10117
T10117
- Ø 1"** 48-T10139
T10139





Static Toolholders - Enhanced Program

- 

OD cutting holder, double, Y axis
 20 (3/4") 48-77726
- 

OD cutting holder, both sides, double, Y axis
 20 (3/4") 48-77727
- 

Face cutting holder, both sides
 20 48-79608
 3/4" 48-79609
- 

Cut-off holder, adjustable
 SH 32 48-98891
- 

Cut-off holder, adjustable, HP-IC
 SH 32 48-102261R IC 80 bar
 SH 32 48-102261L IC 80 bar
- 



Boring bar holder, with slot
 Ø 32 48-82057
 Ø 40 48-82058
 Ø 1 1/4" 48-82059
 Ø 1 1/2" 48-82060
- 

Boring bar holder, double, universal
 Ø 20 48-75406
 Ø 3/4" 48-75416
- 

Combination toolholder, both sides, double, Y axis
 Ø 25 48-80788 IC 80 bar

Static Toolholders - Enhanced Program

- 

Collet face drill holder
 ER 25 48-107230 IC 80 bar
 107525000
 ER 32 48-81031 IC 80 bar
 107532000
- 

VDI adapter, left
 VDI 30 48-77732
- 

VDI adapter, right
 VDI 30 48-78687
- 

Boring bar holder, blank
 48-80506

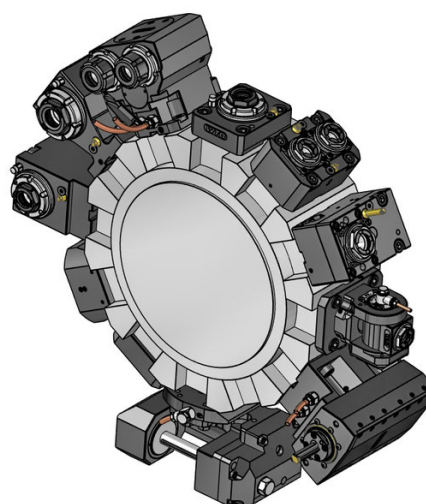
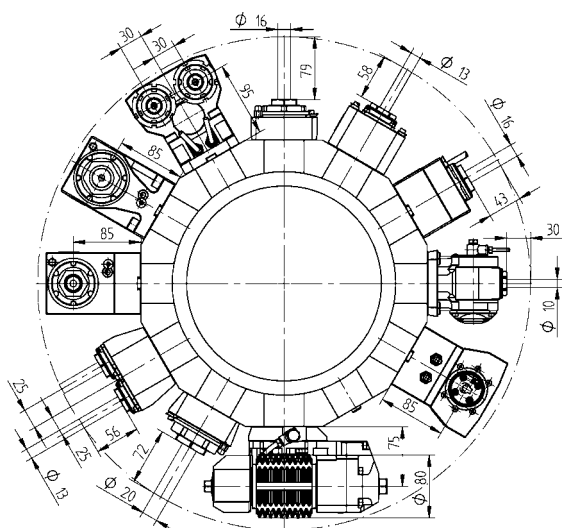

Driven Toolholders - QuickFlex®



OD drill/milling unit (12000 RPM)

ER-25 QF	420125012-40 T32433	1:1	EC
	0067725000		
ER-25 QF	420125013-40	1:1	IC 80 bar
	0067725000		
ER-32 QF	420132099-40	1:1	EC
	0067732000		
ER-32 QF	420132100-40	1:1	IC 80 bar
	0067732000		



OD drill/milling unit (6000 RPM, Heavy Duty)

ER-25 QF	420125010-40 T32274, T32450	1:1	EC
	0067725000		
ER-25 QF	420125011-40 T32287	1:1	IC 80 bar
	0067725000		
ER-32 QF	420132010-40 T32475, T32484	1:1	EC
	0067732000		
ER-32 QF	420132011-40	1:1	IC 80 bar
	0067732000		

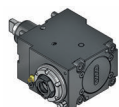

Face drill/milling unit (12000 RPM)

ER-25 QF	420525013-40 T32434	1:1	EC
	0067725000		
ER-25 QF	420525014-40 T32436	1:1	IC 80 bar
	0067725000		
ER-32 QF	420532146-40	1:1	EC
	0067732000		
ER-32 QF	420532147-40	1:1	IC 80 bar
	0067732000		

Driven Toolholders - QuickFlex®



Face drill/milling unit (6000 RPM, Heavy Duty)

ER-25 QF	420525010-40 T32275, T32297	1:1	EC
	0067725000		
ER-25 QF	420525011-40 T32288, T32435	1:1	IC 80 bar
	0067725000		
ER-32 QF	420532010-40 T32476, T32485	1:1	EC
	0067732000		
ER-32 QF	420532011-40	1:1	IC 80 bar
	0067732000		



Face drill/milling unit, both sides (12000 RPM)

ER-25 QF	420525049-40	1:1	EC
	0067725000		
ER-32 QF	420532148-40	1:1	EC
	0067732000		



Face drill/milling unit, both sides (6000 RPM, Heavy Duty)

ER-25 QF	420525012-40 T32276, T32437	1:1	EC
	0067725000		
ER-32 QF	420532012-40	1:1	EC
	0067732000		

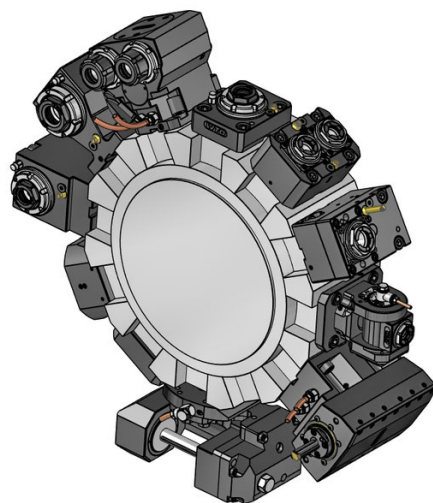
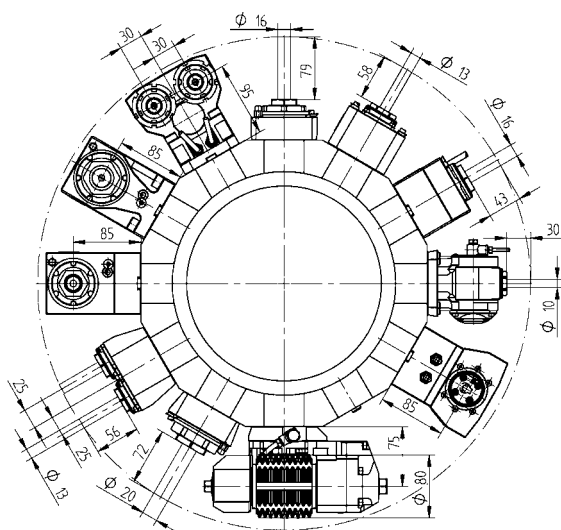

Driven Toolholders - Enhanced Program

Driven Toolholders - Enhanced Program

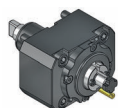

OD milling unit with combination mill arbor DIN 6358

Ø 16	410216010-40	1:1	EC
	00675000854		
Ø 22	410222016-40	1:1	EC
	T32280, T32486		
	00675000483		
Ø 3/4"	410219003-40	1:1	EC
	00675000483		



OD drill/milling unit, offset

ER 25	410116050-40	1:1	EC
	T32279, T32488		
	00675000932		
ER 25	410116057-40	1:1	IC 80 bar
	00675000932		
ER 20	410113060-40	1:2	EC
	00675000939		
ER 20	410113068-40	1:2	IC 80 bar
	00675000939		
ER 16	410410003-40	1:3	EC
	00675000937		
ER 16	410410004-40	1:3	IC 80 bar
	00675000937		
ER 25	410116051-40	2:1	EC
	00675000932		
ER 25	410116058-40	2:1	IC 80 bar
	00675000932		



OD drill/milling unit, offset (12000 RPM)

ER 25	410116060-40	1:1	EC
	00675000932		
ER 25	410116059-40	1:1	IC 80 bar
	00675000932		



Face drill/milling unit

ER-20 QF	420520010-40	1:2	EC
	0067720001		
ER-20 QF	420520011-40	1:2	IC 80 bar
	0067720001		
ER 16	410810012-40	1:3	EC
	0067825001		
ER 16	410810013-40	1:3	IC 80 bar
	0067825001		
ER-32 QF	420532013-40	2:1	EC
	0067732000		
ER-32 QF	420532014-40	2:1	IC 80 bar
	0067732000		

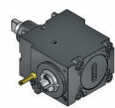

Face milling unit with combination mill arbor DIN 6358

Ø 16	410616013-40	1:1	EC
	00675000854		
Ø 22	410622030-40	1:1	EC
	00675000483		
Ø 22	410622029-40	2:1	EC
	T32292, T32487		
	00675000160		
Ø 3/4"	410619003-40	1:1	EC
	00675000483		
Ø 1"	410625002-40	2:1	EC
	00675000160		

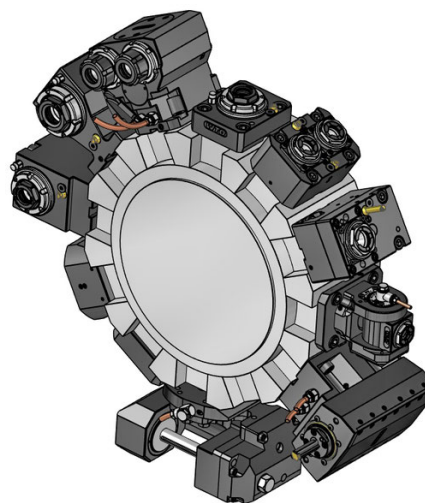
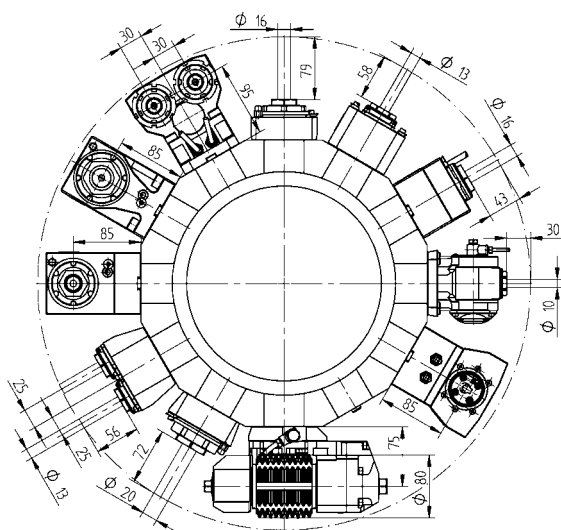

Driven Toolholders - Enhanced Program



Adjustable angle drill/milling unit

ER 16	411010008-40	1:1	EC
	00675000913		
ER 16	411010009-40	1:1	IC 80 bar
	00675000913		
ER 11	411007001-40	1:2	EC
	00675000914		
ER 11	411007002-40	1:2	IC 80 bar
	00675000914		



Gear hobbing unit

Type 16-1	411500017-40	1:1	EC
Type 16-1	411500018-40	2:1	EC
	00675000954		
	160016161 Ø 16		
	160022161 Ø 22		
	160027161 Ø 27		
	160015161 Ø 5/8"		
	160019161 Ø 3/4"		
	160025161 Ø 1"		
	160031161 Ø 1 1/4"		
	110587		



OD drill/milling unit, both sides

ER 20	413002015-40	1:1	EC
	00675000947		
ER 20	413002018-40	1:1	IC 80 bar
	00675000947		



OD drill/milling unit, double, Y axis

ER 20	413002014-40	1:1	EC
	00675000947		
ER 20	413002017-40	1:1	IC 80 bar
	00675000947		

Driven Toolholders - Enhanced Program

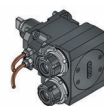

2-spindle - Face drill/milling unit, Y axis

ER 25	413502008-40	1:1	EC
	00675000915		
ER 25	413502009-40	1:1	IC 80 bar
	00675000915		

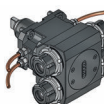

2-spindle - Face drill/milling unit, both sides, Y axis

ER 25	413502007-40	1:1	EC
	00675000915		

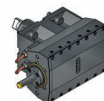

Broaching unit for ID and OD

TN765050	414532000-40	1:1	EC
-----------------	--------------	-----	----

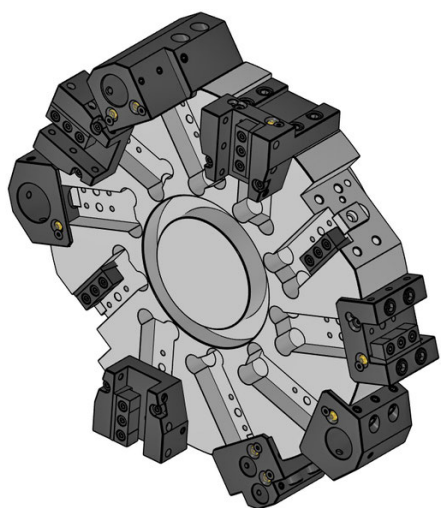
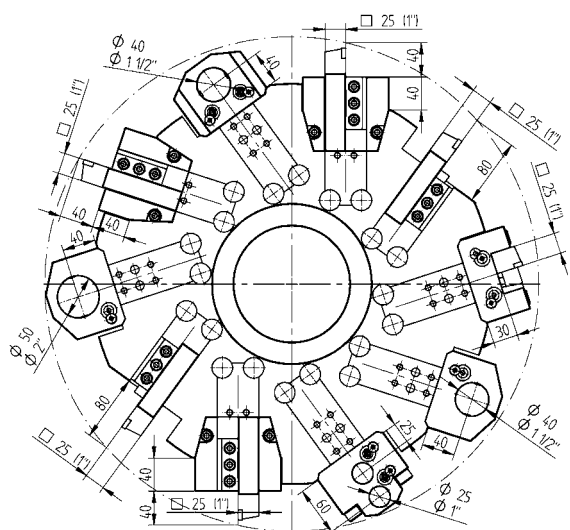

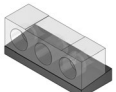

Static Toolholders - Standard Program

 **Wedge block**
25(1") 48-B27036

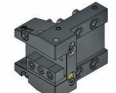
 **Wedge shim**
25 48-B27037
1" 48-B27038

 **OD cutting holder**
25 48-T00074
1" 48-T00075

 **Face cutting holder**
25 48-T00068
1" 48-T00069

 **Boring bar holder**
Ø 40 48-T10036
Ø 50 48-T10044
Ø 1 1/2" 48-T10037
Ø 2" 48-T10045

 **Boring bar holder, extended**
Ø 1 1/2" 48-T10039

 **Combination toolholder**
Ø 40 48-T13064 IC 80 bar
Ø 50 48-83292 IC 80 bar
Ø 1 1/2" 48-T13065 IC 80 bar
Ø 2" 48-83294 IC 80 bar

 **Combination toolholder, extended**
Ø 40 48-T10038 IC 80 bar

Static Toolholders - Enhanced Program

 **Work stopper**
48-T17002

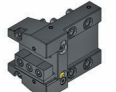
 **OD cutting holder, HP-IC**
25 48-T00074-HP IC 80 bar

 **Face cutting holder, HP-IC**
25 48-T00068-HP IC 80 bar

 **Boring bar holder, double**
Ø 25 48-83452
Ø 1" 48-83592

 **VDI adapter, left**
VDI 30 48-83473

 **VDI adapter, right**
VDI 30 48-49950

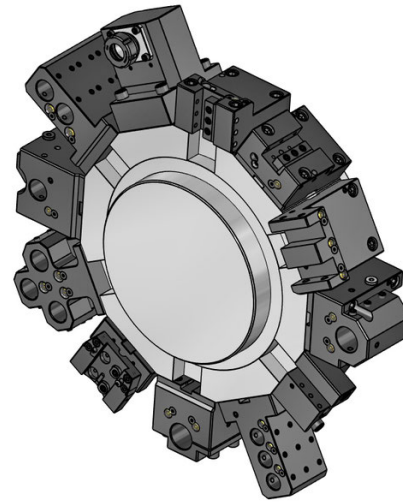
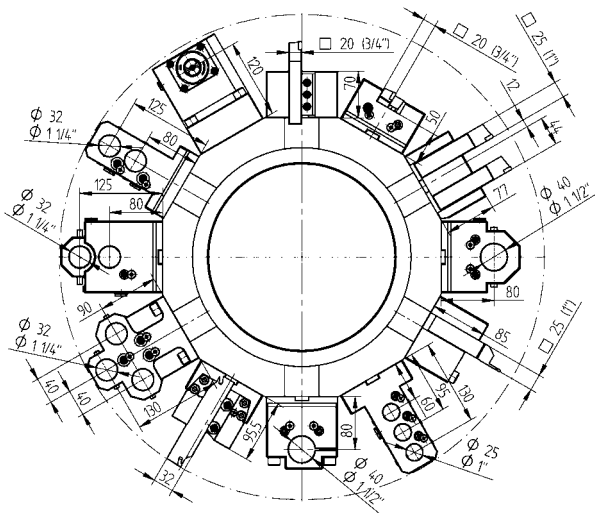

Static Toolholders - Standard Program

Static Toolholders - Standard Program

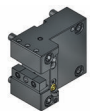

OD cutting holder

- 20 48-T00187
T00187
- 25 48-T00186
T00186
- 3/4" 48-T00203
T00203
- 1" 48-T00202
T00202



OD cutting holder, HP-IC

- 25 48-T00186-HP IC 80 bar
T00186
- 1" 48-T00202-HP IC 80 bar
T00202



OD cutting holder, both sides

- 20 48-T00185
T00185
- 25 48-T00184
T00184
- 3/4" 48-T00201
T00201
- 1" 48-T00199
T00199



OD cutting holder, both sides, HP-IC

- 25 48-T00184-HP IC 80 bar
T00184
- 1" 48-T00199-HP IC 80 bar
T00199

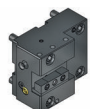

Face cutting holder

- 20 48-T03006
T03006
- 25 48-T03005
T03005
- 3/4" 48-T03014
T03014
- 1" 48-T03013
T03013



Face cutting holder, HP-IC

- 25 48-T03005-HP IC 80 bar
T03005
- 1" 48-T03013-HP IC 80 bar
T03013



Cut-off holder, right hand

- 25 48-T00197
T00197
- 1" 48-T00198
T00198



Boring bar holder, LF=80

- Ø 40 48-T10097
T10097
- Ø 50 48-T10098
T10098
- Ø 1 1/2" 48-T10101
T10101
- Ø 2" 48-T10102
T10102
- Ø 2 1/2" 48-70080



Boring bar holder, LF=120

- Ø 40 48-T10113
T10113
- Ø 50 48-T10114
T10114
- Ø 1 1/2" 48-T10134
T10134
- Ø 2" 48-T10135
T10135



Combination toolholder, LF=80

- Ø 40 48-T13128 IC 80 bar
T13128
- Ø 50 48-T13139 IC 80 bar
T13139
- Ø 1 1/2" 48-T13130 IC 80 bar
T13130
- Ø 2" 48-T13140 IC 80 bar
T13140

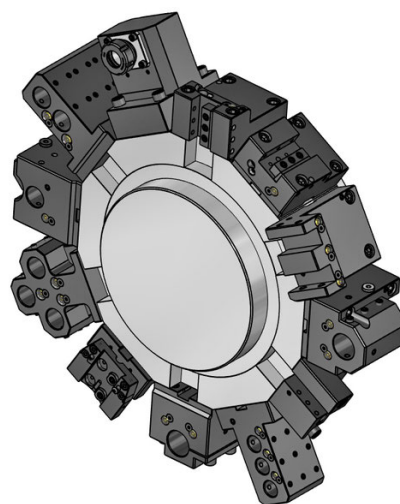
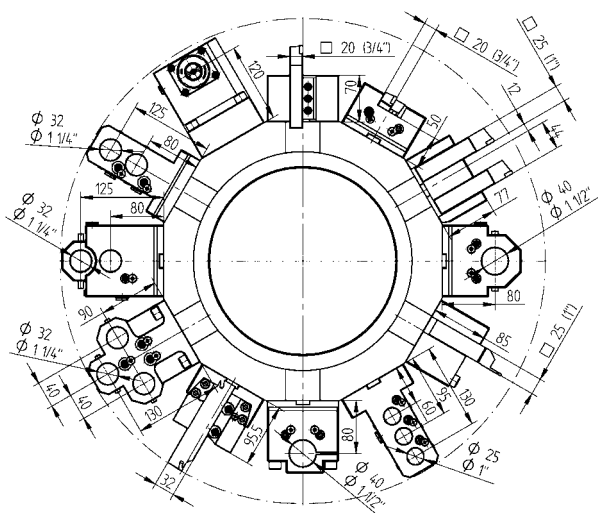

Static Toolholders - Standard Program



Combination toolholder, LF=120

- Ø 40 48-T13131 IC 80 bar
T13131
- Ø 50 48-77902 IC 80 bar
- Ø 1 1/2" 48-T13137 IC 80 bar
T13137
- Ø 2" 48-77901 IC 80 bar



Boring bar holder, both sides

- Ø 32 48-T10096
T10096
- Ø 1 1/4" 48-T10100
T10100
- Ø 1 1/2" 48-89192



Combination toolholder, both sides

- Ø 40 48-89027 IC 80 bar
- Ø 1 1/2" 48-89195 IC 80 bar

Static Toolholders - Enhanced Program

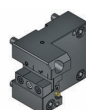

OD cutting holder, right hand, long, HP-IC

- 25 48-T00385-HP IC 80 bar
T00385
- 1" 48-T00386-HP IC 80 bar
T00386



OD cutting holder, left hand, long, HP-IC

- 25 48-T00387-HP IC 80 bar
T00387
- 1" 48-T00388-HP IC 80 bar
T00388

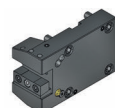

OD cutting holder, short

- 25 48-79591
- 1" 48-79593

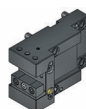

OD cutting holder, extended

- 25 48-T00236
T00236
- 1" 48-T00245
T00245



OD cutting holder (only for NLX 4000)

- 32 48-T00450
T00450
- 1 1/4" 48-T00462
T00462



OD cutting holder, double, Y axis

- 25(1") 48-71865
T00206, T00210

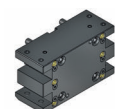

OD cutting holder, both sides, double, Y axis

- 25(1") 48-71863
T00253, T00258

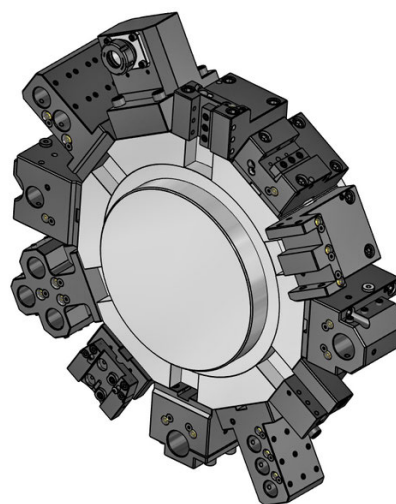
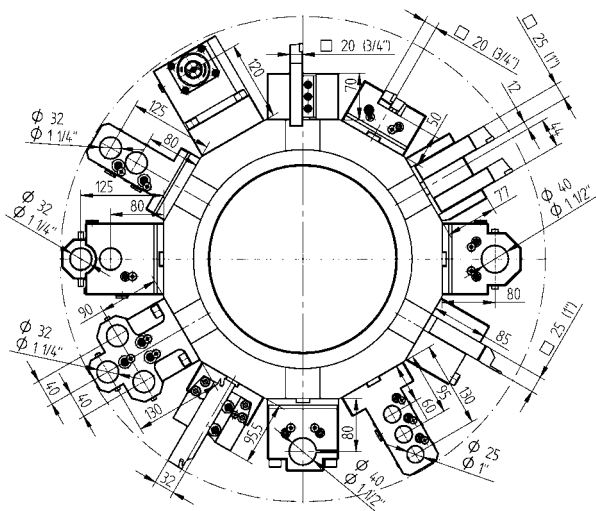

Static Toolholders - Enhanced Program

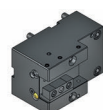

Face cutting holder, extended

- 25** 48-T03019
T03019
- 32** 48-113046
- 1"** 48-T03020
T03020
- 1 1/4"** 48-112853



Face cutting holder, both sides

- 25** 48-78995
- 1"** 48-78996



Cut-off holder, adjustable

- SH 32** 48-98901



Cut-off holder, adjustable, HP-IC

- SH 32** 48-102262R IC 80 bar
- SH 32** 48-102262L IC 80 bar



Cut-off holder, adjustable, extended

- SH 32** 48-77478

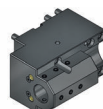

Boring bar holder, extended (only for NLX 4000)

- Ø 40** 48-T13163
T13163
- Ø 50** 48-T13161
T13161
- Ø 1 1/2"** 48-T13164
T13164
- Ø 2"** 48-T13162
T13162

Static Toolholders - Enhanced Program



Boring bar holder, with slot

- Ø 40** 48-T10136
T10136
- Ø 50** 48-T10137
T10137
- Ø 60** 48-70811
- Ø 1 1/2"** 48-T10143
T10143
- Ø 2"** 48-T10142
T10142



Boring bar holder, triple, universal

- Ø 25** 48-T10104
T10104
- Ø 1"** 48-T10107
T10107



Boring bar holder, double, both sides

- Ø 32** 48-71889
- Ø 1 1/4"** 48-72951



Boring bar holder, triple, both sides

- Ø 25** 48-71875
- Ø 1"** 48-72949



Boring bar holder, triple, both sides, Y axis

- Ø 32** 48-85932
- Ø 1 1/4"** 48-101078



Collet face drill holder

- ER 32** 48-94564 IC 80 bar
107532000
- ER 40** 48-94566 IC 80 bar
107540000

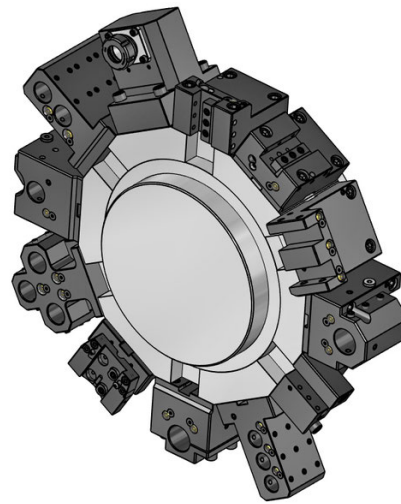
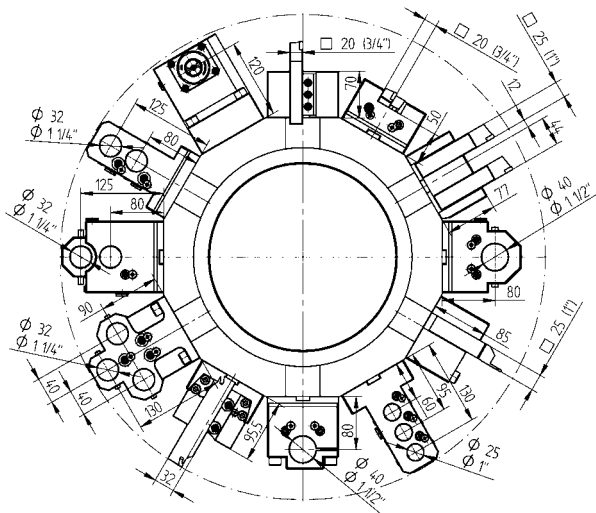

Static Toolholders - Enhanced Program



Collet face drill holder, both sides

- ER 32 48-94565 IC 80 bar
 107532000
- ER 40 48-94567 IC 80 bar
 107540000



VDI adapter, left

- VDI 30 48-77127
- VDI 40 48-72984



VDI adapter, right

- VDI 30 48-74796
- VDI 40 48-77955

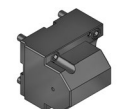

Boring bar holder, blank

- 48-81080

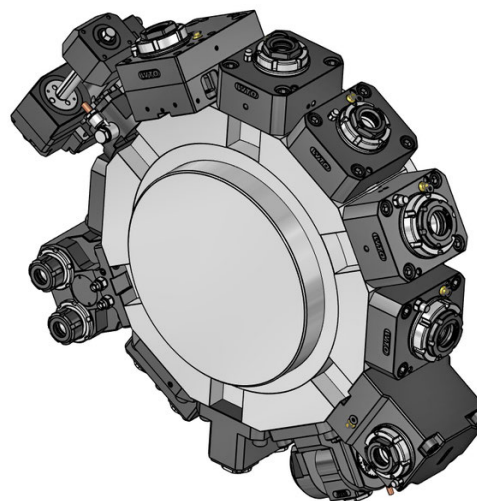
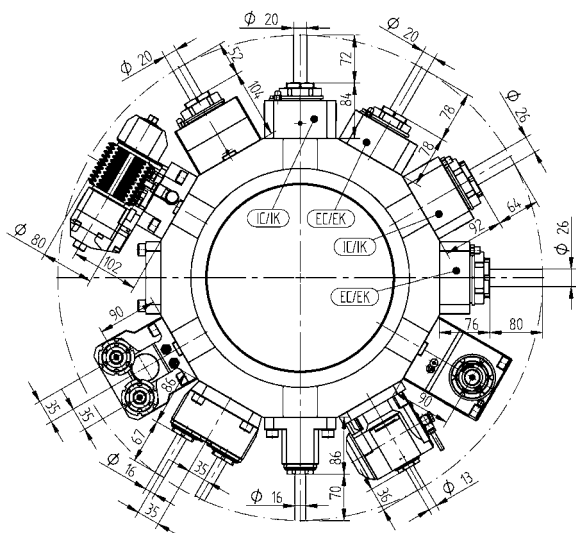

Driven Toolholders - QuickFlex®

Driven Toolholders - QuickFlex®



OD drill/milling unit (10000 RPM)

ER-32 QF 420132018-60 1:1 EC
T32598
0067732000

ER-32 QF 420132023-60 1:1 IC 80 bar
0067732000



OD drill/milling unit (6000 RPM, Heavy Duty)

ER-32 QF 420132010-60 1:1 EC
T32206, T32249
0067732000

ER-32 QF 420132011-60 1:1 IC 80 bar
T32232, T32478
0067732000

ER-40 QF 420140010-60 1:1 EC
T32213
0067740000

ER-40 QF 420140011-60 1:1 IC 80 bar
T32234
0067740000



Face drill/milling unit (10000 RPM)

ER-32 QF 420532030-60 1:1 EC
T32599
0067732000

ER-32 QF 420532031-60 1:1 IC 80 bar
0067732000



Face drill/milling unit (6000 RPM, Heavy Duty)

ER-32 QF 420532010-60 1:1 EC
T32207, T32256
0067732000

ER-32 QF 420532011-60 1:1 IC 80 bar
T32233
0067732000

ER-40 QF 420540012-60 1:1 EC
T32214
0067740000

ER-40 QF 420540013-60 1:1 IC 80 bar
T32235
0067740000



Face drill/milling unit, both sides (10000 RPM)

ER-32 QF 420532041-60 1:1 EC
0067732000



Face drill/milling unit, both sides (6000 RPM, Heavy Duty)

ER-32 QF 420532019-60 1:1 EC
T32216
0067732000

ER-40 QF 420540016-60 1:1 EC
T32248
0067740000

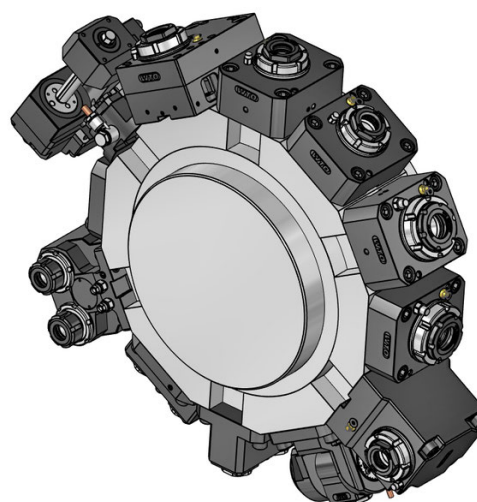
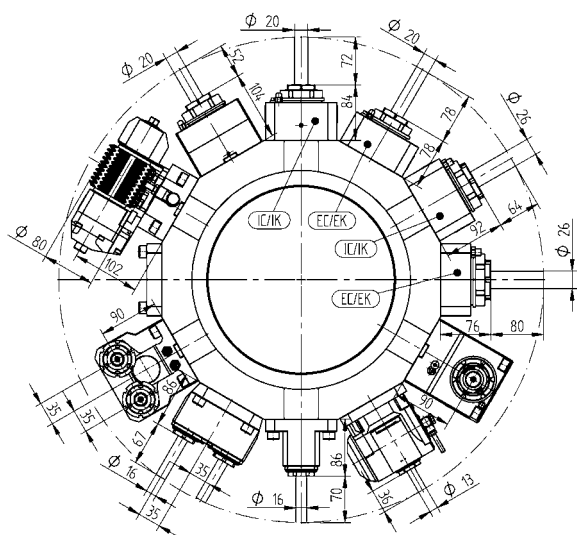

Driven Toolholders - Enhanced Program



OD milling unit with combination mill arbor DIN 6358

Ø 16	410216000-60	1:1	EC
	00675000854		
Ø 22	410222007-60	1:1	EC
	T32268		
	00675000483		
Ø 27	410227008-60	1:1	EC
	00675000245		
Ø 3/4"	410219000-60	1:1	EC
	00675000483		
Ø 1"	410225000-60	1:1	EC
	T32217		
	00675000483		



OD drill/milling unit, offset

ER-32 QF	420132019-60	1:1	EC
	0067732000		
ER-32 QF	420132020-60	1:1	IC 80 bar
	0067732000		
ER-25 QF	420125010-60	1:2	EC
	0067725001		
ER-25 QF	420125011-60	1:2	IC 80 bar
	0067725001		
ER-32 QF	420132021-60	2:1	EC
	0067732000		
ER-32 QF	420132022-60	2:1	IC 80 bar
	0067732000		

Driven Toolholders - Enhanced Program



Face drill/milling unit

ER-25 QF	420525010-60	1:2	EC
	0067725001		
ER-25 QF	420525011-60	1:2	IC 80 bar
	0067725001		
ER-40 QF	420540014-60	2:1	EC
	0067740000		
ER-40 QF	420540015-60	2:1	IC 80 bar
	0067740000		

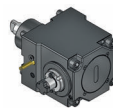

Face milling unit with combination mill arbor DIN 6358

Ø 22	410622000-60	2:1	EC
	T32269		
	00675000483		
Ø 27	410627000-60	2:1	EC
	00675000245		
Ø 1"	410625000-60	2:1	EC
	T32226		
	00675000483		



Adjustable angle drill/milling unit

ER 20	411013009-60	1:1	EC
	T32474		
	00675000928		
ER 20	411013010-60	1:1	IC 80 bar
	00675000928		
ER 16	411010001-60	1:2	EC
	00675000936		
ER 16	411010002-60	1:2	IC 80 bar
	00675000936		

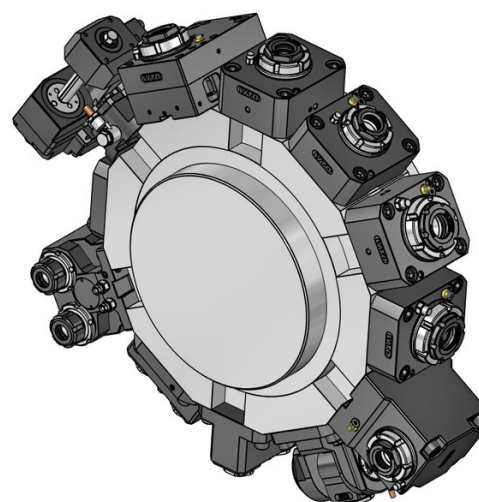
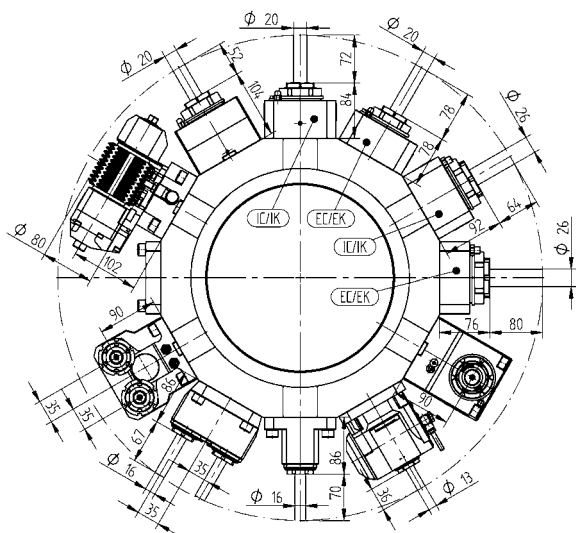

Driven Toolholders - Enhanced Program

Driven Toolholders - Enhanced Program



Slitting saw unit

- Type 19-2** 411500006-60 3:1 EC
 00675000855
 160022192 Ø 22
 160027192 Ø 27
 160032192 Ø 32
 160040192 Ø 40
 160023192 Ø 7/8"
 160025192 Ø 1"
 160031192 Ø 1 1/4"
 160038192 Ø 1 1/2"



Gear hobbing unit

- Type 16-1** 411500007-60 1:1 EC
Type 16-1 411500008-60 2:1 EC
 00675000926
 160016161 Ø 16
 160022161 Ø 22
 160027161 Ø 27
 160015161 Ø 5/8"
 160019161 Ø 3/4"
 160025161 Ø 1"
 160031161 Ø 1 1/4"
 110587



OD drill/milling unit, both sides

- ER 25** 413002001-60 1:1 EC
 00675000907



OD drill/milling unit, double, Y axis

- ER 25** 413002000-60 1:1 EC
 T32267
 00675000907

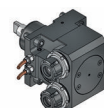

2-spindle - Face drill/milling unit, Y axis

- ER 25** 413502000-60 1:1 EC
 T32264
 00675000915
ER 25 413502002-60 1:1 IC 80 bar
 00675000915

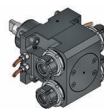

2-spindle - Face drill/milling unit, both sides, Y axis

- ER 25** 413502001-60 1:1 EC
 00675000915



4-spindle - Face drill/milling unit, both sides

- ER 20** 413504000-60 1:1 EC
 00675000974

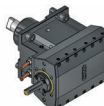

Broaching unit for ID and OD

- TN765050** 414532000-60 1:1 EC



Power Skiving Unit (only for NLX 1500-3000 MC/Y/SMC/SY)

- Hydraulic** 414920000-60 1:1 EC
 106445

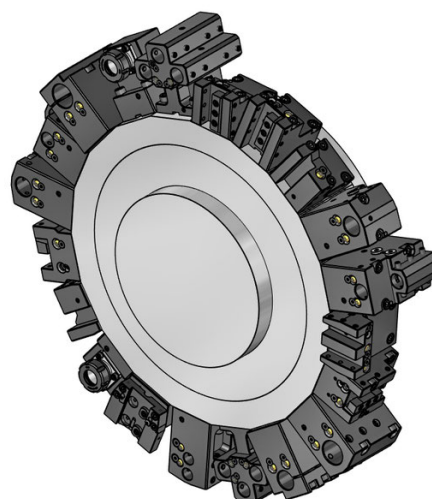
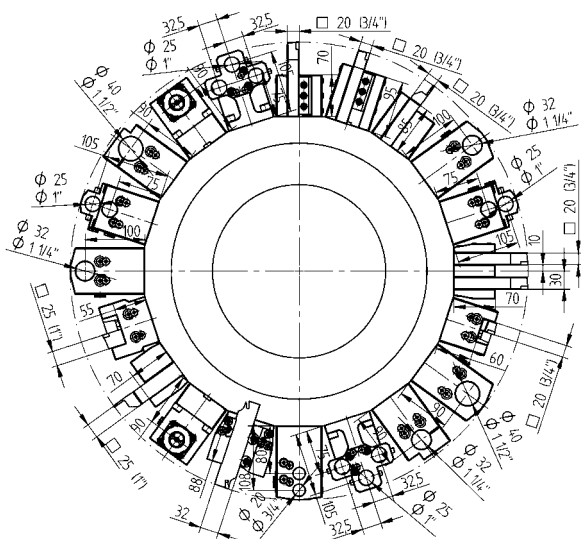

Static Toolholders - Standard Program



OD cutting holder, short

- 20** 48-T00224
T00224
- 25** 48-T00267
T00267
- 3/4"** 48-T00234
T00234
- 1"** 48-T00272
T00272



OD cutting holder, short, HP-IC

- 20** 48-T00224-HP IC 80 bar
T00224
- 25** 48-T00267-HP IC 80 bar
T00267
- 3/4"** 48-T00234-HP IC 80 bar
T00234
- 1"** 48-T00272-HP IC 80 bar
T00272



OD cutting holder, long

- 20** 48-T00225
T00225
- 3/4"** 48-T00235
T00235

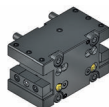

OD cutting holder, both sides, short

- 20** 48-T00228
T00228
- 25** 48-86523
- 3/4"** 48-T00250
T00250
- 1"** 48-86524



OD cutting holder, both sides, short, HP-IC

- 20** 48-T00228-HP IC 80 bar
T00228
- 25** 48-86523-HP IC 80 bar
- 3/4"** 48-T00250-HP IC 80 bar
T00250
- 1"** 48-86524-HP IC 80 bar

Static Toolholders - Standard Program



OD cutting holder, both sides, long

- 20** 48-T00226
T00226
- 3/4"** 48-T00249
T00249



Face cutting holder

- 25** 48-T03024
T03024
- 3/4"** 48-T03018
T03018
- 1"** 48-T03025
T03025



Face cutting holder, HP-IC

- 20** 48-T03017-HP IC 80 bar
T03017
- 3/4"** 48-T03018-HP IC 80 bar
T03018



Cut-off holder, right hand

- 20** 48-T00251
T00251
- 25** 48-T00268
T00268, T00356
- 3/4"** 48-T00252
T00252
- 1"** 48-T00359
T00359, T00357



Combination toolholder

- Ø 32** 48-T13132 IC 80 bar
T13132
- Ø 40** 48-77999 IC 80 bar
- Ø 1 1/4"** 48-T13135 IC 80 bar
T13135
- Ø 1 1/2"** 48-80016 IC 80 bar



Boring bar holder, both sides

- Ø 25** 48-T10117
T10117
- Ø 1"** 48-T10139
T10139

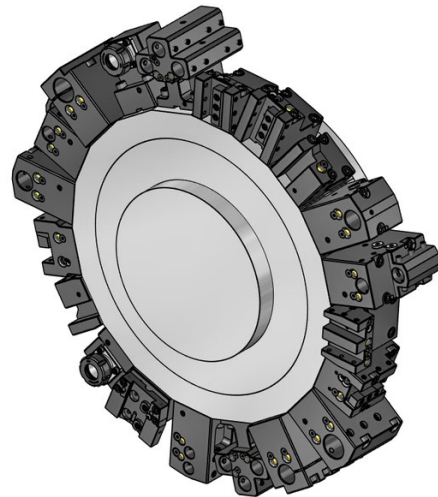
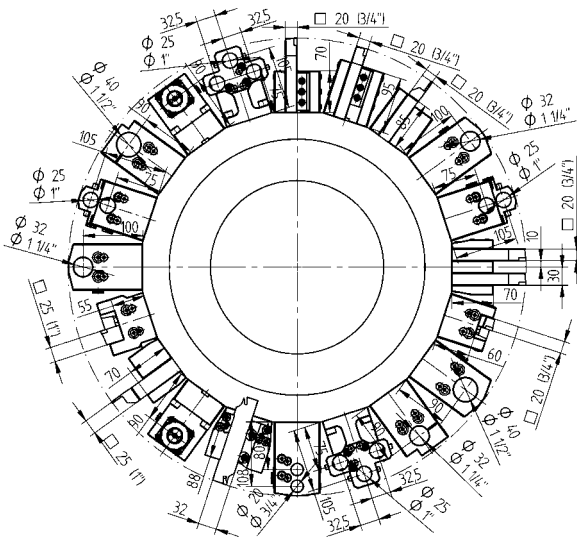

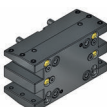

Static Toolholders - Enhanced Program

- 

OD cutting holder, double, Y axis
20 (3/4") 48-77726
- 

OD cutting holder, both sides, double, Y axis
20 (3/4") 48-77727
- 

Face cutting holder, both sides
20 48-79608
3/4" 48-79609
- 

Cut-off holder, adjustable
SH 32 48-98891
- 

Cut-off holder, adjustable, HP-IC
SH 32 48-102261R IC 80 bar
SH 32 48-102261L IC 80 bar
- 

Boring bar holder, with slot
Ø 32 48-82057
Ø 40 48-82058
Ø 1 1/4" 48-82059
Ø 1 1/2" 48-82060
- 

Boring bar holder, double, universal
Ø 20 48-75406
Ø 3/4" 48-75416
- 

Boring bar holder, double, both sides
Ø 20 48-75404
Ø 3/4" 48-75417

Static Toolholders - Enhanced Program

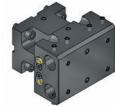
- 

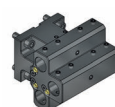
Combination toolholder, both sides, double, Y axis
Ø 25 48-80788 IC 80 bar
- 

Combination toolholder, both sides, triple, Y axis
Ø 25 48-85908 IC 80 bar
Ø 1" 48-85985 IC 80 bar
- 

Collet face drill holder
ER 25 48-107230 IC 80 bar
107525000
ER 32 48-81031 IC 80 bar
107532000
- 

Collet face drill holder, both sides
ER 25 48-107227 IC 80 bar
107525000
ER 32 48-80509 IC 80 bar
107532000
- 

VDI adapter, left
VDI 30 48-77732
- 

VDI adapter, right
VDI 30 48-78687
- 

Boring bar holder, blank
48-80506

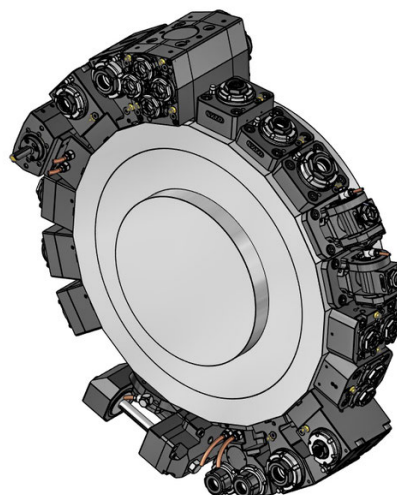
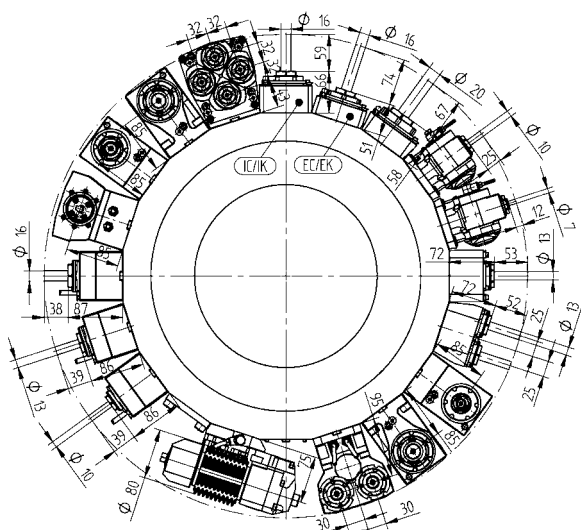

Driven Toolholders - QuickFlex®



OD drill/milling unit (12000 RPM)

ER-25 QF	420125012-40 T32433	1:1	EC
	0067725000		
ER-25 QF	420125013-40	1:1	IC 80 bar
	0067725000		
ER-32 QF	420132099-40	1:1	EC
	0067732000		
ER-32 QF	420132100-40	1:1	IC 80 bar
	0067732000		



OD drill/milling unit (6000 RPM, Heavy Duty)

ER-25 QF	420125010-40 T32274, T32450	1:1	EC
	0067725000		
ER-25 QF	420125011-40 T32287	1:1	IC 80 bar
	0067725000		
ER-32 QF	420132010-40 T32475, T32484	1:1	EC
	0067732000		
ER-32 QF	420132011-40	1:1	IC 80 bar
	0067732000		



Face drill/milling unit (12000 RPM)

ER-25 QF	420525013-40 T32434	1:1	EC
	0067725000		
ER-25 QF	420525014-40 T32436	1:1	IC 80 bar
	0067725000		
ER-32 QF	420532146-40	1:1	EC
	0067732000		
ER-32 QF	420532147-40	1:1	IC 80 bar
	0067732000		

Driven Toolholders - QuickFlex®



Face drill/milling unit (6000 RPM, Heavy Duty)

ER-25 QF	420525010-40 T32275, T32297	1:1	EC
	0067725000		
ER-25 QF	420525011-40 T32288, T32435	1:1	IC 80 bar
	0067725000		
ER-32 QF	420532010-40 T32476, T32485	1:1	EC
	0067732000		
ER-32 QF	420532011-40	1:1	IC 80 bar
	0067732000		



Face drill/milling unit, both sides (12000 RPM)

ER-25 QF	420525049-40	1:1	EC
	0067725000		
ER-32 QF	420532148-40	1:1	EC
	0067732000		



Face drill/milling unit, both sides (6000 RPM, Heavy Duty)

ER-25 QF	420525012-40 T32276, T32437	1:1	EC
	0067725000		
ER-32 QF	420532012-40	1:1	EC
	0067732000		

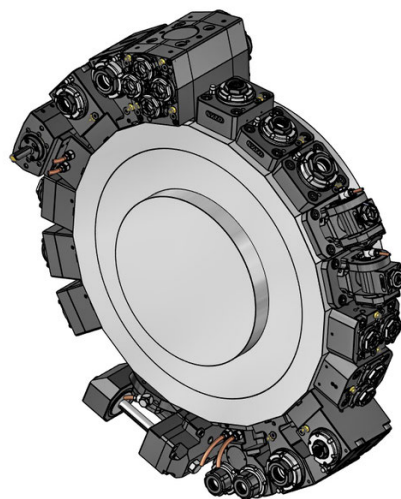
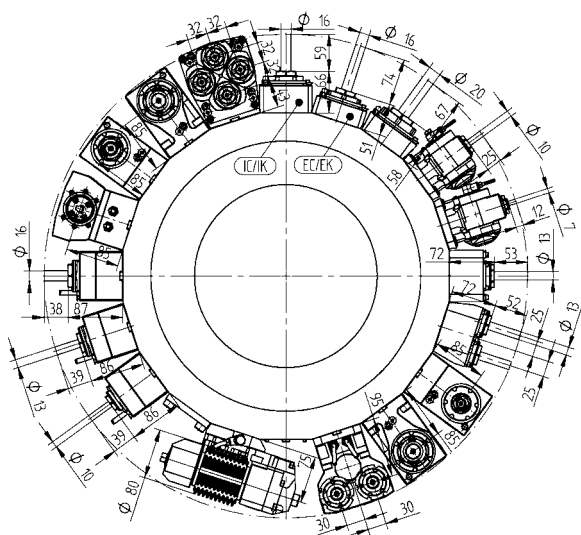

Driven Toolholders - Enhanced Program

Driven Toolholders - Enhanced Program

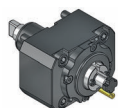

OD milling unit with combination mill arbor DIN 6358

Ø 16	410216010-40	1:1	EC
	00675000854		
Ø 22	410222016-40	1:1	EC
	T32280, T32486		
	00675000483		
Ø 3/4"	410219003-40	1:1	EC
	00675000483		



OD drill/milling unit, offset

ER 25	410116050-40	1:1	EC
	T32279, T32488		
	00675000932		
ER 25	410116057-40	1:1	IC 80 bar
	00675000932		
ER 20	410113060-40	1:2	EC
	00675000939		
ER 20	410113068-40	1:2	IC 80 bar
	00675000939		
ER 16	410410003-40	1:3	EC
	00675000937		
ER 16	410410004-40	1:3	IC 80 bar
	00675000937		
ER 25	410116051-40	2:1	EC
	00675000932		
ER 25	410116058-40	2:1	IC 80 bar
	00675000932		



OD drill/milling unit, offset (12000 RPM)

ER 25	410116060-40	1:1	EC
	00675000932		
ER 25	410116059-40	1:1	IC 80 bar
	00675000932		



Face drill/milling unit

ER-20 QF	420520010-40	1:2	EC
	0067720001		
ER-20 QF	420520011-40	1:2	IC 80 bar
	0067720001		
ER 16	410810012-40	1:3	EC
	0067825001		
ER 16	410810013-40	1:3	IC 80 bar
	0067825001		
ER-32 QF	420532013-40	2:1	EC
	0067732000		
ER-32 QF	420532014-40	2:1	IC 80 bar
	0067732000		

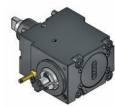

Face milling unit with combination mill arbor DIN 6358

Ø 16	410616013-40	1:1	EC
	00675000854		
Ø 22	410622030-40	1:1	EC
	00675000483		
Ø 22	410622029-40	2:1	EC
	T32292, T32487		
	00675000160		
Ø 3/4"	410619003-40	1:1	EC
	00675000483		
Ø 1"	410625002-40	2:1	EC
	00675000160		



Face back set drill/milling unit

ER 25	410516153-40	1:1	EC
	00675000801		
ER 25	410516154-40	1:1	IC 80 bar
	00675000801		

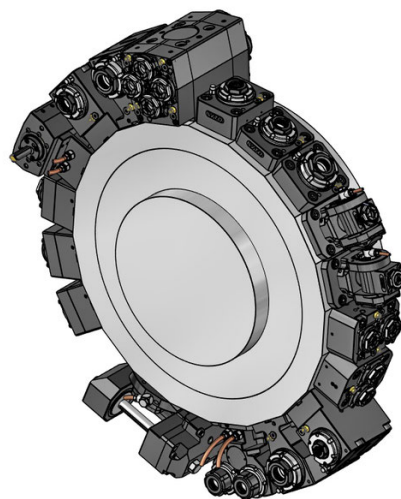
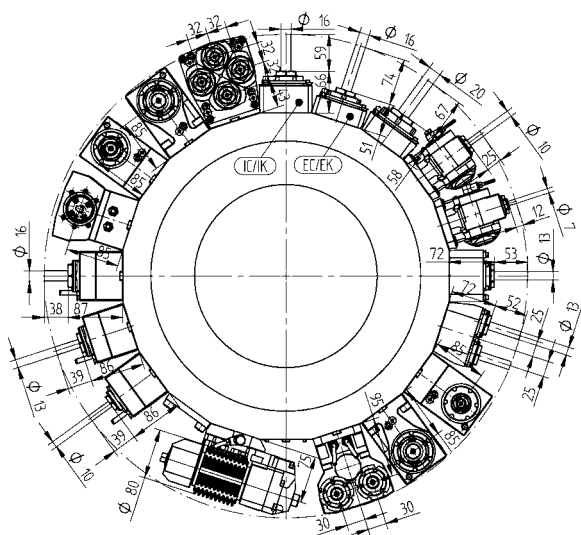

Driven Toolholders - Enhanced Program



Adjustable angle drill/milling unit

ER 16	411010008-40	1:1	EC
	00675000913		
ER 16	411010009-40	1:1	IC 80 bar
	00675000913		
ER 11	411007001-40	1:2	EC
	00675000914		
ER 11	411007002-40	1:2	IC 80 bar
	00675000914		



Gear hobbing unit

Type 16-1	411500017-40	1:1	EC
Type 16-1	411500018-40	2:1	EC
	00675000954		
	160016161 Ø 16		
	160022161 Ø 22		
	160027161 Ø 27		
	160015161 Ø 5/8"		
	160019161 Ø 3/4"		
	160025161 Ø 1"		
	160031161 Ø 1 1/4"		
	110587		



OD drill/milling unit, both sides

ER 20	413002015-40	1:1	EC
	00675000947		
ER 20	413002018-40	1:1	IC 80 bar
	00675000947		



OD drill/milling unit, double, Y axis

ER 20	413002014-40	1:1	EC
	00675000947		
ER 20	413002017-40	1:1	IC 80 bar
	00675000947		

Driven Toolholders - Enhanced Program

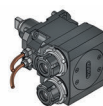

2-spindle - Face drill/milling unit, Y axis

ER 25	413502008-40	1:1	EC
	00675000915		
ER 25	413502009-40	1:1	IC 80 bar
	00675000915		

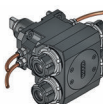

2-spindle - Face drill/milling unit, both sides, Y axis

ER 25	413502007-40	1:1	EC
	00675000915		



4-spindle - Face drill/milling unit

ER 20	413504001-40	1:1	EC
	00675000947		



4-spindle - Face drill/milling unit, both sides

ER 20	413504000-40	1:1	EC
	00675000947		



Broaching unit for ID and OD

TN765050	414532000-40	1:1	EC
-----------------	--------------	-----	----

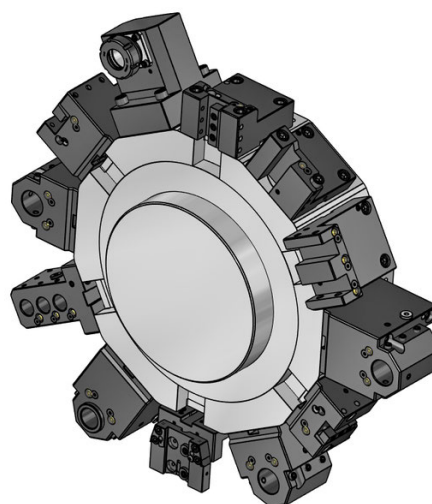
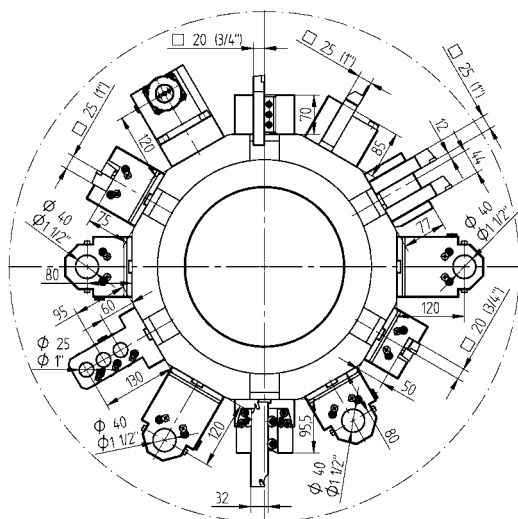

Static Toolholders - Standard Program

Static Toolholders - Standard Program

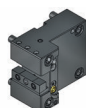

OD cutting holder

20	48-T00187 T00187
25	48-T00186 T00186
3/4"	48-T00203 T00203
1"	48-T00202 T00202



OD cutting holder, HP-IC

25	48-T00186-HP	IC 80 bar
	T00186	
1"	48-T00202-HP	IC 80 bar
	T00202	

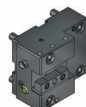

Face cutting holder

20	48-T03006 T03006
25	48-T03005 T03005
3/4"	48-T03014 T03014
1"	48-T03013 T03013



Face cutting holder, HP-IC

25	48-T03005-HP	IC 80 bar
	T03005	
1"	48-T03013-HP	IC 80 bar
	T03013	



Cut-off holder, right hand

25	48-T00197 T00197
1"	48-T00198 T00198



Combination toolholder, LF=80

Ø 40	48-T13128 T13128	IC 80 bar
Ø 50	48-T13139 T13139	IC 80 bar
Ø 1 1/2"	48-T13130 T13130	IC 80 bar
Ø 2"	48-T13140 T13140	IC 80 bar



Combination toolholder, LF=120

Ø 40	48-T13131 T13131	IC 80 bar
Ø 50	48-77902	IC 80 bar
Ø 1 1/2"	48-T13137 T13137	IC 80 bar
Ø 2"	48-77901	IC 80 bar

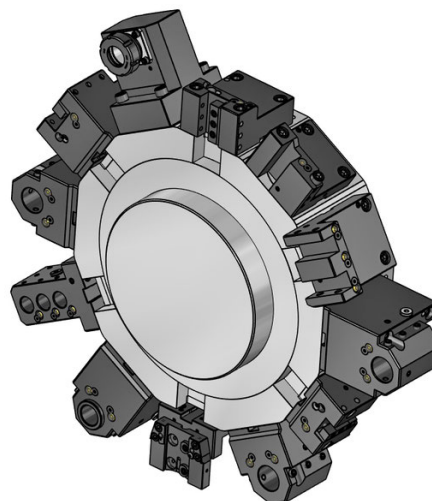
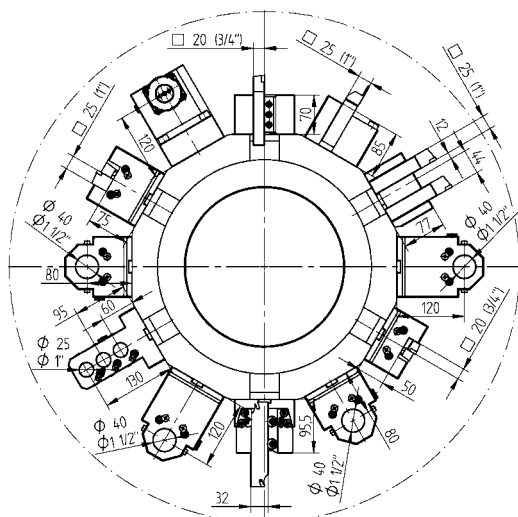

Static Toolholders - Enhanced Program

Static Toolholders - Enhanced Program

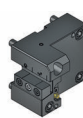
- 

OD cutting holder, right hand, long, HP-IC

25	48-T00385-HP	IC 80 bar
	T00385	
1"	48-T00386-HP	IC 80 bar
	T00386	
- 

OD cutting holder, left hand, long, HP-IC

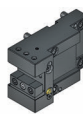
25	48-T00387-HP	IC 80 bar
	T00387	
1"	48-T00388-HP	IC 80 bar
	T00388	
- 

OD cutting holder, extended

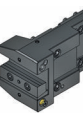
25	48-T00236	
	T00236	
1"	48-T00245	
	T00245	
- 

OD cutting holder (only for NLX 4000)

32	48-T00450	
	T00450	
1 1/4"	48-T00462	
	T00462	
- 

OD cutting holder, double, Y axis

25(1")	48-71865	
	T00206, T00210	
- 

Face cutting holder, extended

25	48-T03019	
	T03019	
32	48-113046	
1"	48-T03020	
	T03020	
1 1/4"	48-112853	
- 

Cut-off holder, adjustable

SH 32	48-98901	
-------	----------	--

- 

Cut-off holder, adjustable, HP-IC

SH 32	48-102262R	IC 80 bar
SH 32	48-102262L	IC 80 bar
- 

Cut-off holder, adjustable, extended

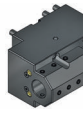
SH 32	48-77478	
-------	----------	--
- 

Boring bar holder, extended (only for NLX 4000)

Ø 40	48-T13163	
	T13163	
Ø 50	48-T13161	
	T13161	
Ø 1 1/2"	48-T13164	
	T13164	
Ø 2"	48-T13162	
	T13162	
- 

Boring bar holder, with slot

Ø 40	48-T10136	
	T10136	
Ø 50	48-T10137	
	T10137	
Ø 60	48-70811	
Ø 1 1/2"	48-T10143	
	T10143	
Ø 2"	48-T10142	
	T10142	
- 

Boring bar holder, triple, universal

Ø 25	48-T10104	
	T10104	
Ø 1"	48-T10107	
	T10107	
- 

Collet face drill holder

ER 32	48-94564	IC 80 bar
	107532000	
ER 40	48-94566	IC 80 bar
	107540000	

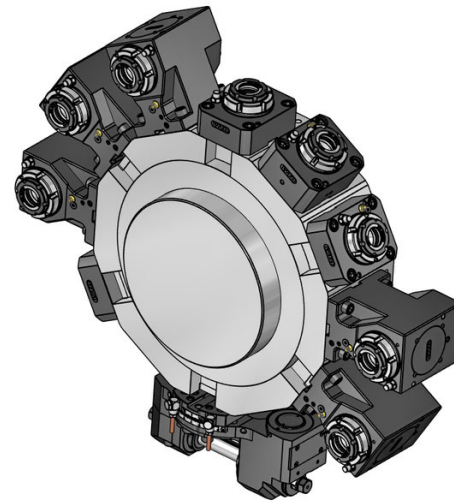
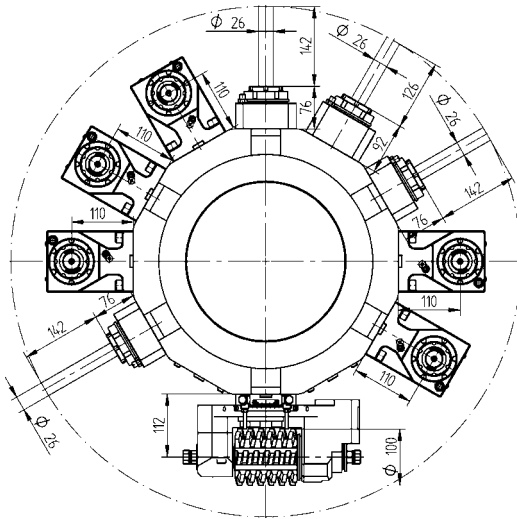

Driven Toolholders - QuickFlex®

Driven Toolholders - Enhanced Program



OD drill/milling unit (High Torque)

ER-40 QF 420140014-60 1:1 EC
T32544

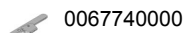

ER-40 QF 420140015-60 1:1 IC 80 bar

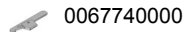

Face drill/milling unit (High Torque)

ER-40 QF 420540017-60 1:1 EC
T32546

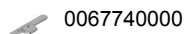

ER-40 QF 420540018-60 1:1 IC 80 bar

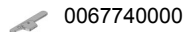

Gear hobbing unit

Type C5-1 410900003-60 2:1 EC

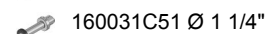
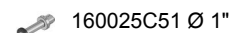
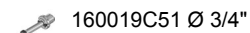
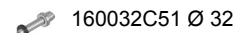
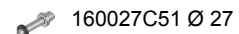
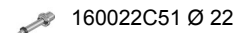
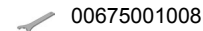

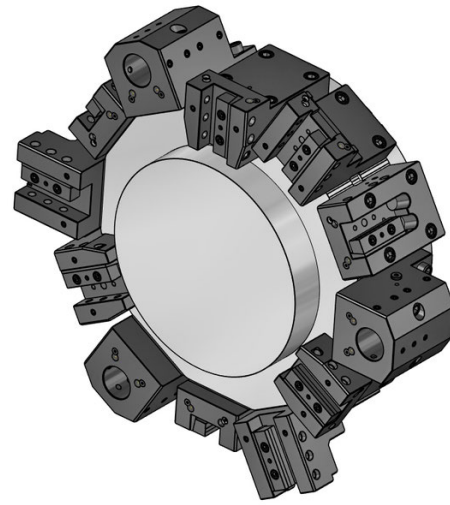
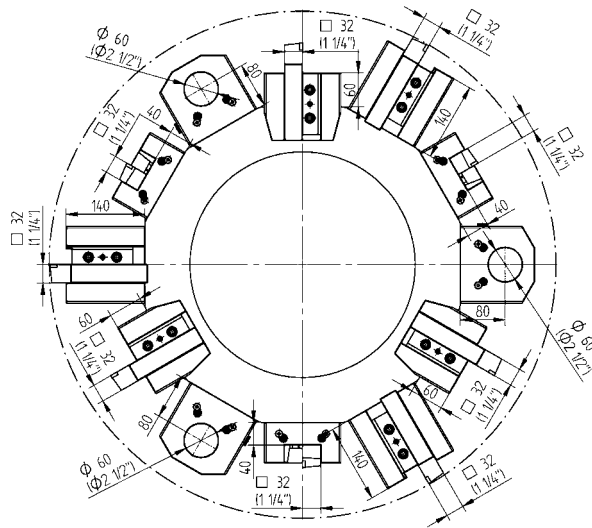

Static Toolholders - Standard Program

Static Toolholders - Enhanced Program



OD cutting holder

- 32** 48-T00432
T00432
- 1 1/4"** 48-T00433
T00433



OD cutting holder, long (only for turret 1)

- 32** 48-T00434
T00434
- 1 1/4"** 48-T00435
T00435

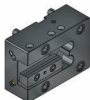

Face cutting holder

- 32** 48-T03042
T03042
- 1 1/4"** 48-T03043
T03043



Combination toolholder

- Ø 60** 48-T10203 IC 80 bar
T10203
- Ø 2 1/2"** 48-T10204 IC 80 bar
T10204



Boring bar holder, with slot

- Ø 60** 48-108639

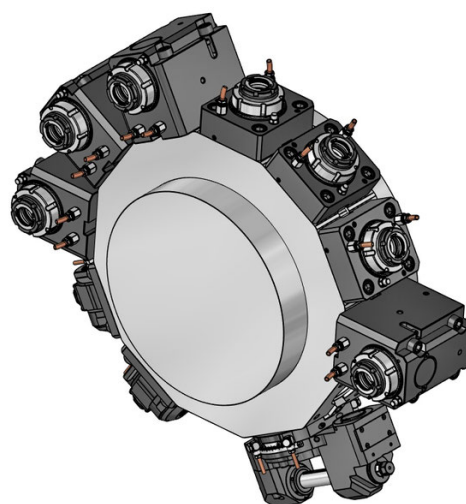
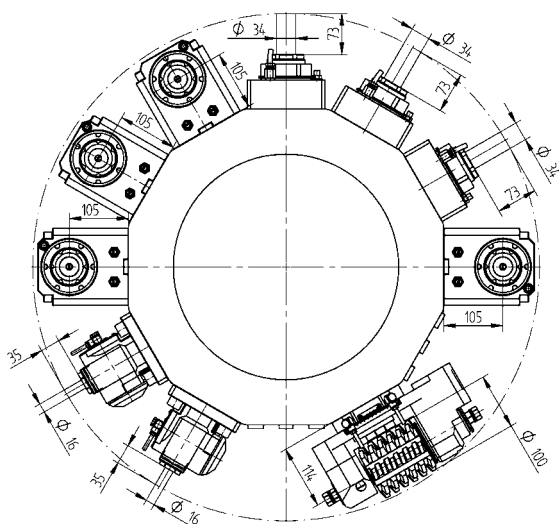

Driven Toolholders - QuickFlex®



OD drill/milling unit (3500 RPM, Heavy Duty)

ER-50 QF 420150010-75 1:1 EC
T32526
0067750000

ER-50 QF 420150011-75 1:1 IC 80 bar
T32547
0067750000



OD drill/milling unit (8000 RPM)

ER-50 QF 420150012-75 1:1 EC
0067750000

ER-50 QF 420150013-75 1:1 IC 80 bar
0067750000

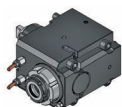

Face drill/milling unit (3500 RPM, Heavy Duty)

ER-50 QF 420550010-75 1:1 EC
T32527
0067750000

ER-50 QF 420550011-75 1:1 IC 80 bar
T32535
0067750000

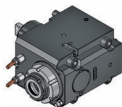

Face drill/milling unit (8000 RPM)

ER-50 QF 420550012-75 1:1 EC
0067750000

ER-50 QF 420550013-75 1:1 IC 80 bar
0067750000

Driven Toolholders - Enhanced Program



Adjustable angle drill/milling unit

ER 25 411016002-75 1:1 EC
00675000934

ER 25 411016003-75 1:1 IC 80 bar
00675000934

ER 16 411010004-75 1:2 EC
00675000936

ER 16 411010005-75 1:2 IC 80 bar
00675000936



Gear hobbing unit

Type C5-1 410900000-75 2:1 EC
00675001008

160022C51 Ø 22

160027C51 Ø 27

160032C51 Ø 32

160019C51 Ø 3/4"

160025C51 Ø 1"

160031C51 Ø 1 1/4"

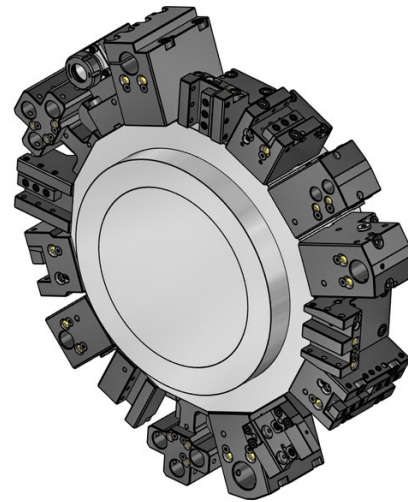
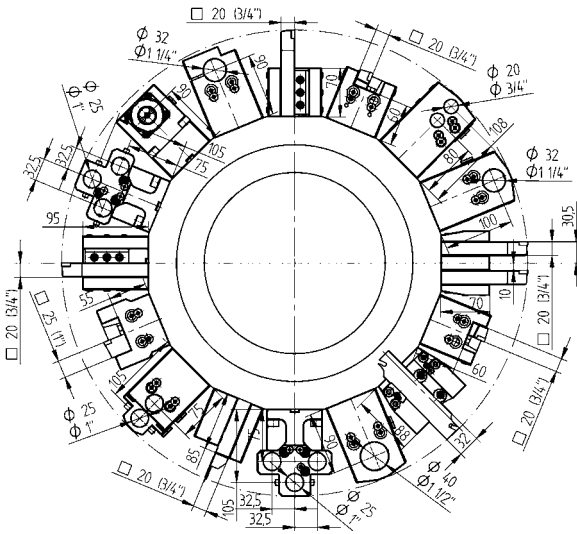

Static Toolholders - Standard Program

Static Toolholders - Standard Program



OD cutting holder, short

- 20 48-T00224
T00224
- 25 48-T00267
T00267
- 3/4" 48-T00234
T00234
- 1" 48-T00272
T00272



OD cutting holder, short, HP-IC

- 20 48-T00224-HP IC 80 bar
T00224
- 25 48-T00267-HP IC 80 bar
T00267
- 3/4" 48-T00234-HP IC 80 bar
T00234
- 1" 48-T00272-HP IC 80 bar
T00272



OD cutting holder, long

- 20 48-T00225
T00225
- 3/4" 48-T00235
T00235

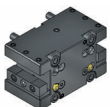

OD cutting holder, both sides, short

- 20 48-T00228
T00228
- 25 48-86523
- 3/4" 48-T00250
T00250
- 1" 48-86524



OD cutting holder, both sides, short, HP-IC

- 20 48-T00228-HP IC 80 bar
T00228
- 25 48-86523-HP IC 80 bar
- 3/4" 48-T00250-HP IC 80 bar
T00250
- 1" 48-86524-HP IC 80 bar



OD cutting holder, both sides, long

- 20 48-T00226
T00226
- 3/4" 48-T00249
T00249



Face cutting holder

- 25 48-T03024
T03024
- 3/4" 48-T03018
T03018
- 1" 48-T03025
T03025



Face cutting holder, HP-IC

- 20 48-T03017-HP IC 80 bar
T03017
- 3/4" 48-T03018-HP IC 80 bar
T03018



Cut-off holder, right hand

- 20 48-T00251
T00251
- 25 48-T00268
T00268, T00356
- 3/4" 48-T00252
T00252
- 1" 48-T00359
T00359, T00357



Combination toolholder

- Ø 32 48-T13132 IC 80 bar
T13132
- Ø 40 48-77999 IC 80 bar
- Ø 1 1/4" 48-T13135 IC 80 bar
T13135
- Ø 1 1/2" 48-80016 IC 80 bar



Boring bar holder, both sides

- Ø 25 48-T10117
T10117
- Ø 1" 48-T10139
T10139

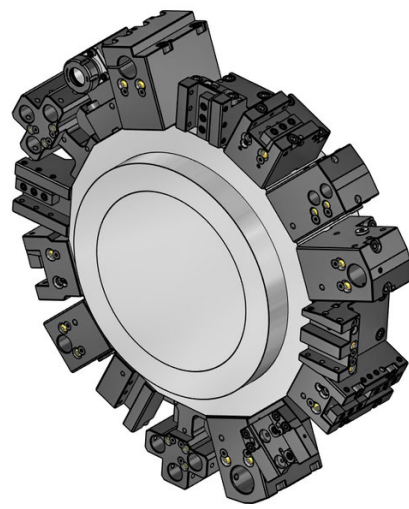
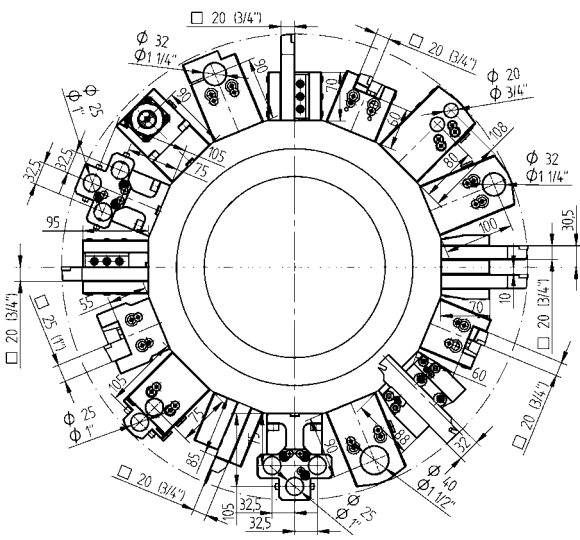

Static Toolholders - Enhanced Program

- 

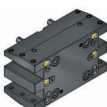
OD cutting holder, double, Y axis
 20 (3/4") 48-77726
- 

OD cutting holder, both sides, double, Y axis
 20 (3/4") 48-77727
- 

Face cutting holder, both sides
 20 48-79608
 3/4" 48-79609
- 

Cut-off holder, adjustable
 SH 32 48-98891
- 

Cut-off holder, adjustable, HP-IC
 SH 32 48-102261R IC 80 bar
 SH 32 48-102261L IC 80 bar
- 

Boring bar holder, with slot
 Ø 32 48-82057
 Ø 40 48-82058
 Ø 1 1/4" 48-82059
 Ø 1 1/2" 48-82060
- 

Boring bar holder, double, universal
 Ø 20 48-75406
 Ø 3/4" 48-75416
- 



Boring bar holder, double, both sides
 Ø 20 48-75404
 Ø 3/4" 48-75417



Static Toolholders - Enhanced Program

- 

Combination toolholder, both sides, double, Y axis
 Ø 25 48-80788 IC 80 bar
- 

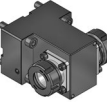
Combination toolholder, both sides, triple, Y axis
 Ø 25 48-85908 IC 80 bar
 Ø 1" 48-85985 IC 80 bar
- 

Collet face drill holder
 ER 25 48-107230 IC 80 bar
 107525000
 ER 32 48-81031 IC 80 bar
 107532000
- 

Collet face drill holder, both sides
 ER 25 48-107227 IC 80 bar
 107525000
 ER 32 48-80509 IC 80 bar
 107532000
- 

VDI adapter, left
 VDI 30 48-77732
- 

VDI adapter, right
 VDI 30 48-78687
- 

Boring bar holder, blank
 48-80506

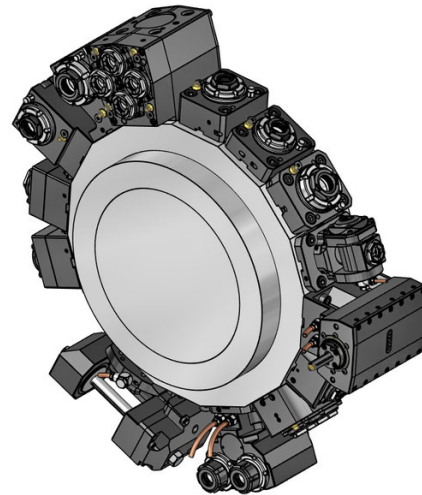
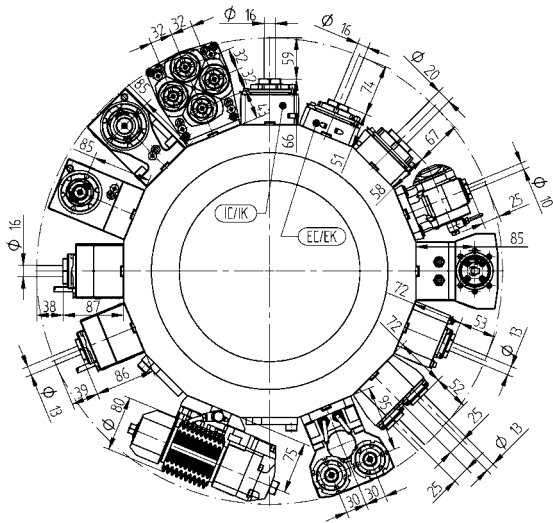

Driven Toolholders - QuickFlex®



OD drill/milling unit (12000 RPM)

ER-25 QF	420125012-40 T32433	1:1	EC
	0067725000		
ER-25 QF	420125013-40	1:1	IC 80 bar
	0067725000		
ER-32 QF	420132099-40	1:1	EC
	0067732000		
ER-32 QF	420132100-40	1:1	IC 80 bar
	0067732000		



OD drill/milling unit (6000 RPM, Heavy Duty)

ER-25 QF	420125010-40 T32274, T32450	1:1	EC
	0067725000		
ER-25 QF	420125011-40 T32287	1:1	IC 80 bar
	0067725000		
ER-32 QF	420132010-40 T32475, T32484	1:1	EC
	0067732000		
ER-32 QF	420132011-40	1:1	IC 80 bar
	0067732000		



Face drill/milling unit (12000 RPM)

ER-25 QF	420525013-40 T32434	1:1	EC
	0067725000		
ER-25 QF	420525014-40 T32436	1:1	IC 80 bar
	0067725000		
ER-32 QF	420532146-40	1:1	EC
	0067732000		
ER-32 QF	420532147-40	1:1	IC 80 bar
	0067732000		

Driven Toolholders - QuickFlex®



Face drill/milling unit (6000 RPM, Heavy Duty)

ER-25 QF	420525010-40 T32275, T32297	1:1	EC
	0067725000		
ER-25 QF	420525011-40 T32288, T32435	1:1	IC 80 bar
	0067725000		
ER-32 QF	420532010-40 T32476, T32485	1:1	EC
	0067732000		
ER-32 QF	420532011-40	1:1	IC 80 bar
	0067732000		



Face drill/milling unit, both sides (12000 RPM)

ER-25 QF	420525049-40	1:1	EC
	0067725000		
ER-32 QF	420532148-40	1:1	EC
	0067732000		



Face drill/milling unit, both sides (6000 RPM, Heavy Duty)

ER-25 QF	420525012-40 T32276, T32437	1:1	EC
	0067725000		
ER-32 QF	420532012-40	1:1	EC
	0067732000		

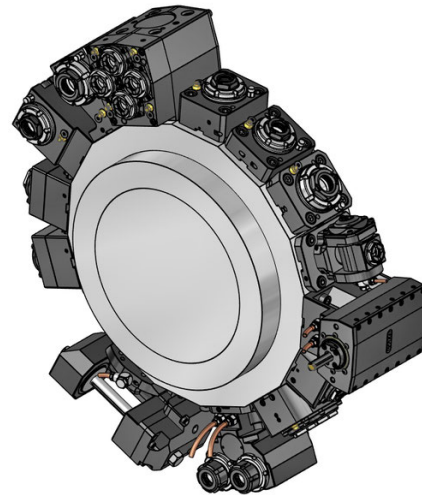
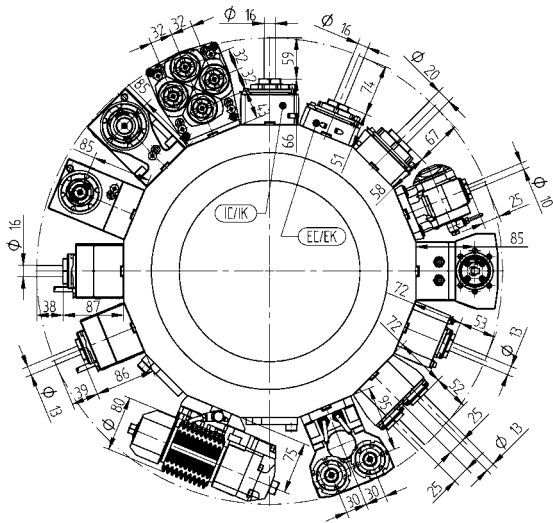

Driven Toolholders - Enhanced Program

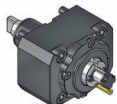

OD milling unit with combination mill arbor DIN 6358

Ø 16	410216010-40	1:1	EC
	00675000854		
Ø 22	410222016-40	1:1	EC
	T32280, T32486		
	00675000483		
Ø 3/4"	410219003-40	1:1	EC
	00675000483		



OD drill/milling unit, offset

ER 25	410116050-40	1:1	EC
	T32279, T32488		
	00675000932		
ER 25	410116057-40	1:1	IC 80 bar
	00675000932		
ER 20	410113060-40	1:2	EC
	00675000939		
ER 20	410113068-40	1:2	IC 80 bar
	00675000939		
ER 16	410410003-40	1:3	EC
	00675000937		
ER 16	410410004-40	1:3	IC 80 bar
	00675000937		
ER 25	410116051-40	2:1	EC
	00675000932		
ER 25	410116058-40	2:1	IC 80 bar
	00675000932		



OD drill/milling unit, offset (12000 RPM)

ER 25	410116060-40	1:1	EC
	00675000932		
ER 25	410116059-40	1:1	IC 80 bar
	00675000932		

Driven Toolholders - Enhanced Program



Face drill/milling unit

ER-20 QF	420520010-40	1:2	EC
	0067720001		
ER-20 QF	420520011-40	1:2	IC 80 bar
	0067720001		
ER 16	410810012-40	1:3	EC
	0067825001		
ER 16	410810013-40	1:3	IC 80 bar
	0067825001		
ER-32 QF	420532013-40	2:1	EC
	0067732000		
ER-32 QF	420532014-40	2:1	IC 80 bar
	0067732000		

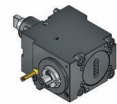

Face milling unit with combination mill arbor DIN 6358

Ø 16	410616013-40	1:1	EC
	00675000854		
Ø 22	410622030-40	1:1	EC
	00675000483		
Ø 22	410622029-40	2:1	EC
	T32292, T32487		
	00675000160		
Ø 3/4"	410619003-40	1:1	EC
	00675000483		
Ø 1"	410625002-40	2:1	EC
	00675000160		



Face back set drill/milling unit

ER 25	410516153-40	1:1	EC
	00675000801		
ER 25	410516154-40	1:1	IC 80 bar
	00675000801		

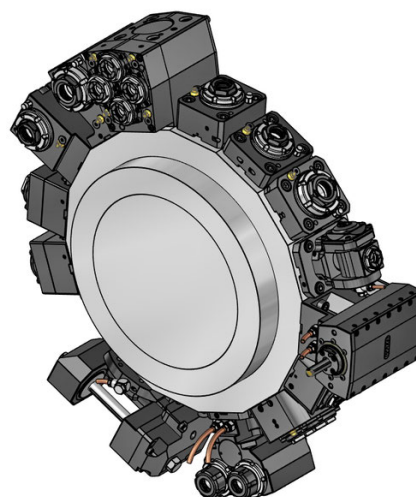
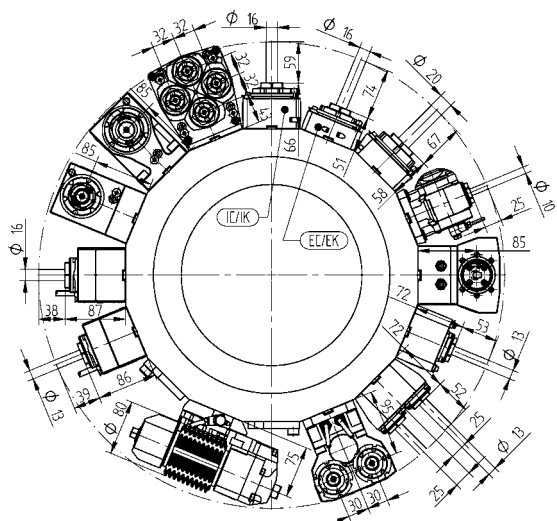

Driven Toolholders - Enhanced Program



Adjustable angle drill/milling unit

ER 16	411010008-40	1:1	EC
	00675000913		
ER 16	411010009-40	1:1	IC 80 bar
	00675000913		
ER 11	411007001-40	1:2	EC
	00675000914		
ER 11	411007002-40	1:2	IC 80 bar
	00675000914		



Gear hobbing unit

Type 16-1	411500017-40	1:1	EC
Type 16-1	411500018-40	2:1	EC
	00675000954		
	160016161 Ø 16		
	160022161 Ø 22		
	160027161 Ø 27		
	160015161 Ø 5/8"		
	160019161 Ø 3/4"		
	160025161 Ø 1"		
	160031161 Ø 1 1/4"		
	110587		



OD drill/milling unit, both sides

ER 20	413002015-40	1:1	EC
	00675000947		
ER 20	413002018-40	1:1	IC 80 bar
	00675000947		



OD drill/milling unit, double, Y axis

ER 20	413002014-40	1:1	EC
	00675000947		
ER 20	413002017-40	1:1	IC 80 bar
	00675000947		

Driven Toolholders - Enhanced Program

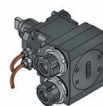

2-spindle - Face drill/milling unit, Y axis

ER 25	413502008-40	1:1	EC
	00675000915		
ER 25	413502009-40	1:1	IC 80 bar
	00675000915		

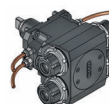

2-spindle - Face drill/milling unit, both sides, Y axis

ER 25	413502007-40	1:1	EC
	00675000915		

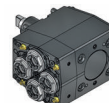

4-spindle - Face drill/milling unit

ER 20	413504001-40	1:1	EC
	00675000947		

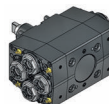

4-spindle - Face drill/milling unit, both sides

ER 20	413504000-40	1:1	EC
	00675000947		

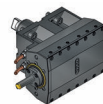

Broaching unit for ID and OD

TN765050	414532000-40	1:1	EC
-----------------	--------------	-----	----

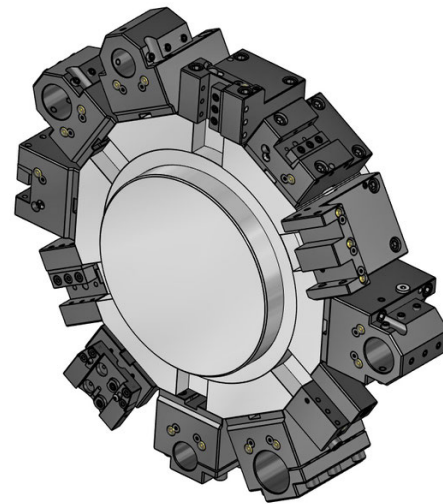
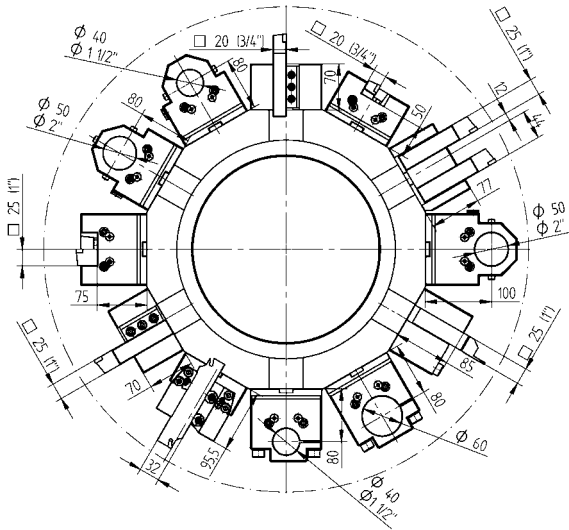

Static Toolholders - Standard Program

Static Toolholders - Standard Program

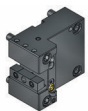

OD cutting holder

- 20** 48-T00187
T00187
- 25** 48-T00186
T00186
- 3/4"** 48-T00203
T00203
- 1"** 48-T00202
T00202



OD cutting holder, HP-IC

- 25** 48-T00186-HP IC 80 bar
T00186
- 1"** 48-T00202-HP IC 80 bar
T00202

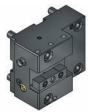

Face cutting holder

- 20** 48-T03006
T03006
- 25** 48-T03005
T03005
- 3/4"** 48-T03014
T03014
- 1"** 48-T03013
T03013



Face cutting holder, HP-IC

- 25** 48-T03005-HP IC 80 bar
T03005
- 1"** 48-T03013-HP IC 80 bar
T03013



Cut-off holder, right hand

- 25** 48-T00197
T00197
- 1"** 48-T00198
T00198



Boring bar holder, LF=80

- Ø 40** 48-T10097
T10097
- Ø 50** 48-T10098
T10098
- Ø 1 1/2"** 48-T10101
T10101
- Ø 2"** 48-T10102
T10102
- Ø 2 1/2"** 48-70080



Boring bar holder, LF=100

- Ø 40** 48-T10181
T10181
- Ø 50** 48-T10185
T10185
- Ø 1 1/2"** 48-T10195
T10195
- Ø 2"** 48-T10186
T10186



Combination toolholder, LF=80

- Ø 40** 48-T13128 IC 80 bar
T13128
- Ø 50** 48-T13139 IC 80 bar
T13139
- Ø 1 1/2"** 48-T13130 IC 80 bar
T13130
- Ø 2"** 48-T13140 IC 80 bar
T13140



Combination toolholder, LF=100

- Ø 40** 48-110098 IC 80 bar
- Ø 50** 48-110099 IC 80 bar
- Ø 1 1/2"** 48-110414 IC 80 bar
- Ø 2"** 48-110415 IC 80 bar

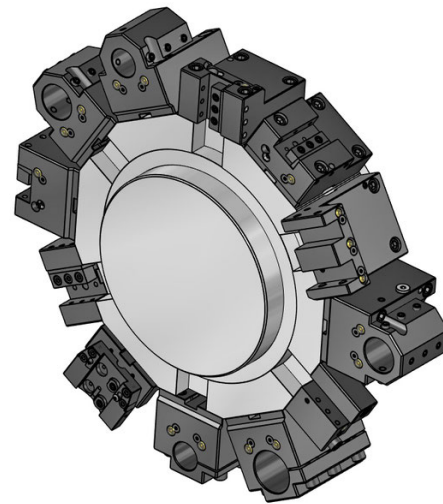
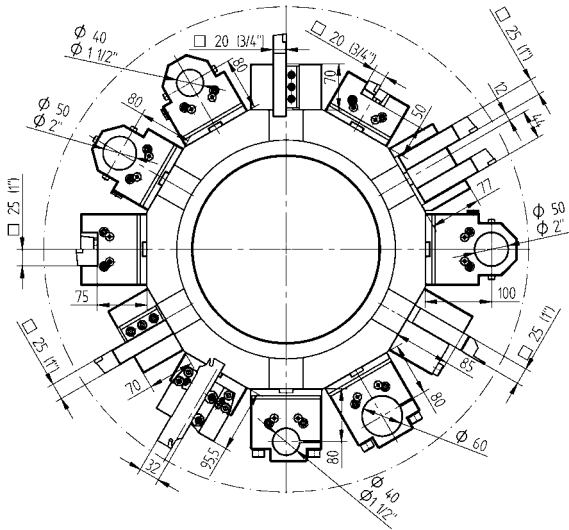

Static Toolholders - Enhanced Program

Static Toolholders - Enhanced Program

- 

OD cutting holder, right hand, long, HP-IC

25	48-T00385-HP	IC 80 bar
	T00385	
1"	48-T00386-HP	IC 80 bar
	T00386	
- 

OD cutting holder, left hand, long, HP-IC

25	48-T00387-HP	IC 80 bar
	T00387	
1"	48-T00388-HP	IC 80 bar
	T00388	
- 

OD cutting holder, short

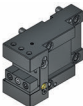
25	48-79591
1"	48-79593
- 

OD cutting holder, extended

25	48-T00236
	T00236
1"	48-T00245
	T00245
- 

OD cutting holder, double, Y axis

25(1")	48-71865
	T00206, T00210
- 

Cut-off holder, adjustable

SH 32	48-98901
--------------	----------
- 

Cut-off holder, adjustable, HP-IC

SH 32	48-102262R	IC 80 bar
SH 32	48-102262L	IC 80 bar
- 

Cut-off holder, adjustable, extended

SH 32	48-77478
--------------	----------

- 

Boring bar holder, with slot

Ø 40	48-T10136
	T10136
Ø 50	48-T10137
	T10137
Ø 60	48-70811
Ø 1 1/2"	48-T10143
	T10143
Ø 2"	48-T10142
	T10142
- 

VDI adapter, left

VDI 30	48-77127
VDI 40	48-72984
- 

VDI adapter, right

VDI 30	48-74796
VDI 40	48-77955
- 

Boring bar holder, blank

48-81080

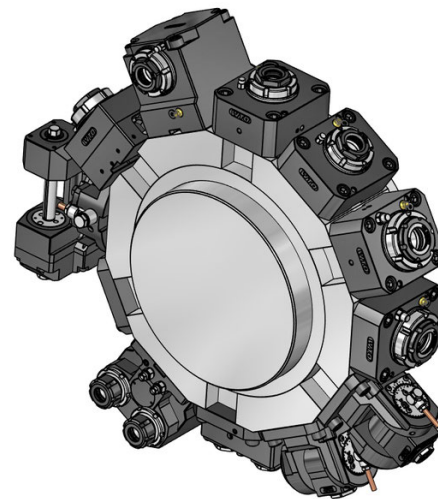
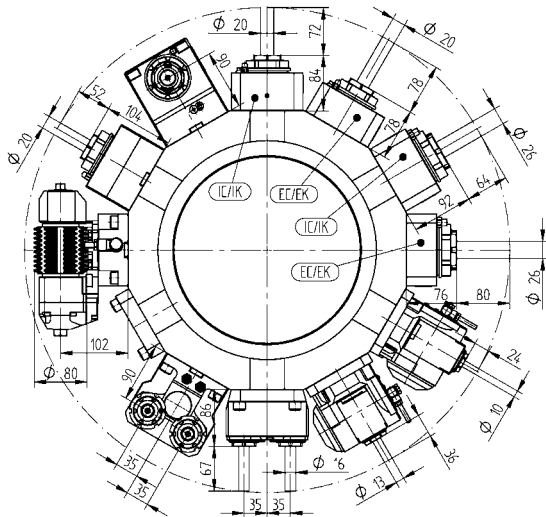

Driven Toolholders - QuickFlex®

Driven Toolholders - QuickFlex®



OD drill/milling unit (10000 RPM)

ER-32 QF 420132018-60 1:1 EC
T32598
0067732000

ER-32 QF 420132023-60 1:1 IC 80 bar
0067732000



OD drill/milling unit (6000 RPM, Heavy Duty)

ER-32 QF 420132010-60 1:1 EC
T32206, T32249
0067732000

ER-32 QF 420132011-60 1:1 IC 80 bar
T32232, T32478
0067732000

ER-40 QF 420140010-60 1:1 EC
T32213
0067740000

ER-40 QF 420140011-60 1:1 IC 80 bar
T32234
0067740000



Face drill/milling unit (10000 RPM)

ER-32 QF 420532030-60 1:1 EC
T32599
0067732000

ER-32 QF 420532031-60 1:1 IC 80 bar
0067732000



Face drill/milling unit (6000 RPM, Heavy Duty)

ER-32 QF 420532010-60 1:1 EC
T32207, T32256
0067732000

ER-32 QF 420532011-60 1:1 IC 80 bar
T32233
0067732000

ER-40 QF 420540012-60 1:1 EC
T32214
0067740000

ER-40 QF 420540013-60 1:1 IC 80 bar
T32235
0067740000

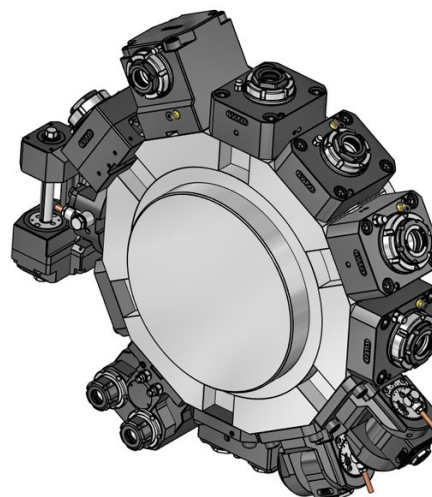
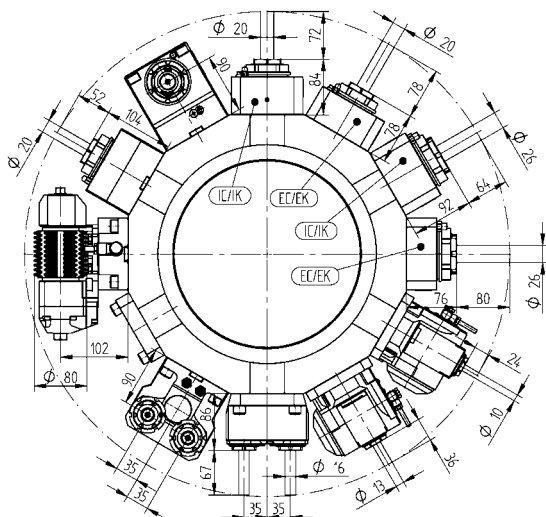

Driven Toolholders - Enhanced Program



OD milling unit with combination mill arbor DIN 6358

Ø 16	410216000-60	1:1	EC
	00675000854		
Ø 22	410222007-60	1:1	EC
	T32268		
	00675000483		
Ø 27	410227008-60	1:1	EC
	00675000245		
Ø 3/4"	410219000-60	1:1	EC
	00675000483		
Ø 1"	410225000-60	1:1	EC
	T32217		
	00675000483		



OD drill/milling unit, offset

ER-32 QF	420132019-60	1:1	EC
	0067732000		
ER-32 QF	420132020-60	1:1	IC 80 bar
	0067732000		
ER-25 QF	420125010-60	1:2	EC
	0067725001		
ER-25 QF	420125011-60	1:2	IC 80 bar
	0067725001		
ER-32 QF	420132021-60	2:1	EC
	0067732000		
ER-32 QF	420132022-60	2:1	IC 80 bar
	0067732000		

Driven Toolholders - Enhanced Program



Face drill/milling unit

ER-25 QF	420525010-60	1:2	EC
	0067725001		
ER-25 QF	420525011-60	1:2	IC 80 bar
	0067725001		
ER-40 QF	420540014-60	2:1	EC
	0067740000		
ER-40 QF	420540015-60	2:1	IC 80 bar
	0067740000		



Face milling unit with combination mill arbor DIN 6358

Ø 22	410622000-60	2:1	EC
	T32269		
	00675000483		
Ø 27	410627000-60	2:1	EC
	00675000245		
Ø 1"	410625000-60	2:1	EC
	T32226		
	00675000483		



Adjustable angle drill/milling unit

ER 20	411013009-60	1:1	EC
	T32474		
	00675000928		
ER 20	411013010-60	1:1	IC 80 bar
	00675000928		
ER 16	411010001-60	1:2	EC
	00675000936		
ER 16	411010002-60	1:2	IC 80 bar
	00675000936		

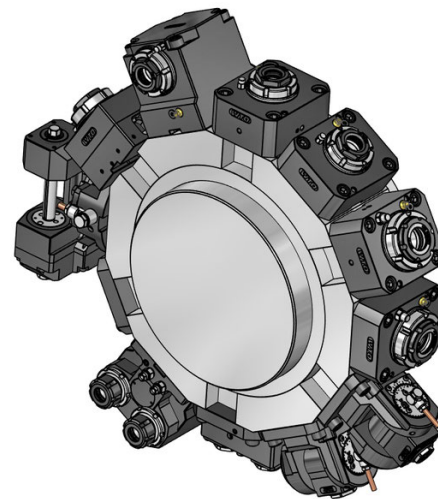
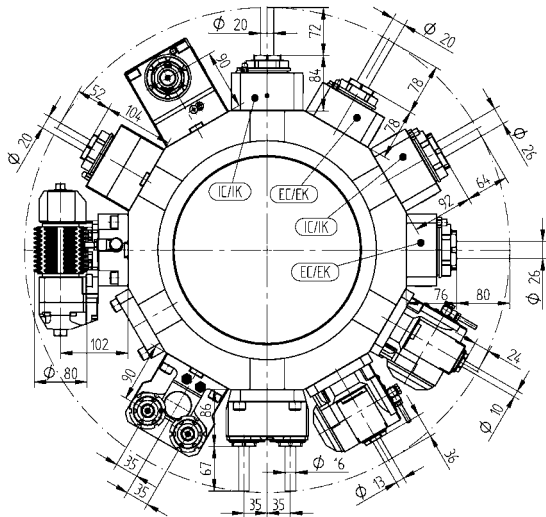

Driven Toolholders - Enhanced Program



Slitting saw unit

Type 19-2	411500006-60	3:1	EC
	00675000855		
	160022192	Ø 22	
	160027192	Ø 27	
	160032192	Ø 32	
	160040192	Ø 40	
	160023192	Ø 7/8"	
	160025192	Ø 1"	
	160031192	Ø 1 1/4"	
	160038192	Ø 1 1/2"	



Gear hobbing unit

Type 16-1	411500007-60	1:1	EC
Type 16-1	411500008-60	2:1	EC
	00675000926		
	160016161	Ø 16	
	160022161	Ø 22	
	160027161	Ø 27	
	160015161	Ø 5/8"	
	160019161	Ø 3/4"	
	160025161	Ø 1"	
	160031161	Ø 1 1/4"	
	110587		



OD drill/milling unit, double, Y axis

ER 25	413002000-60	1:1	EC
	T32267		
	00675000907		

Driven Toolholders - Enhanced Program

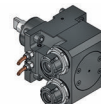

2-spindle - Face drill/milling unit, Y axis

ER 25	413502000-60	1:1	EC
	T32264		
	00675000915		
ER 25	413502002-60	1:1	IC 80 bar
	00675000915		

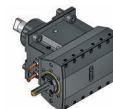

Broaching unit for ID and OD

TN765050	414532000-60	1:1	EC
-----------------	--------------	-----	----

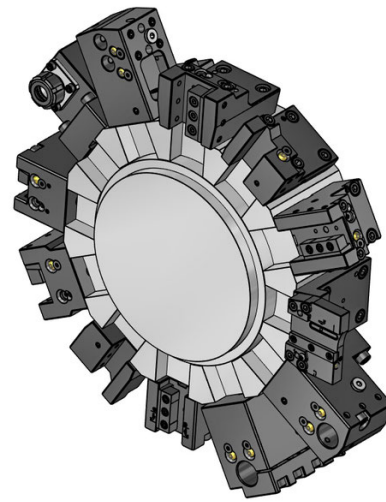
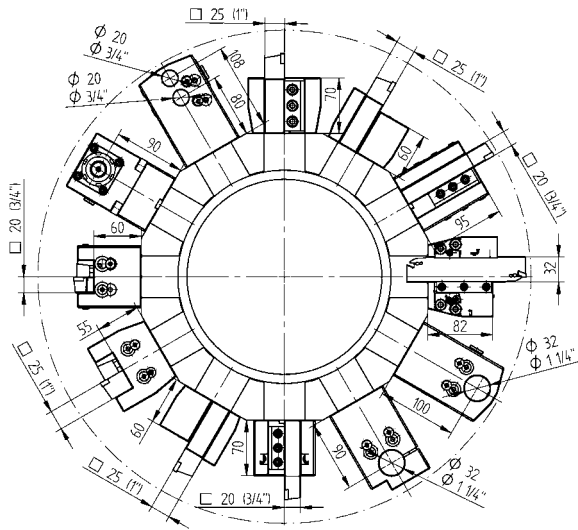

Static Toolholders - Standard Program

Static Toolholders - Standard Program



OD cutting holder, short

20	48-T00224 T00224
25	48-T00267 T00267
3/4"	48-T00234 T00234
1"	48-T00272 T00272



OD cutting holder, short, HP-IC

20	48-T00224-HP	IC 80 bar
	T00224	
25	48-T00267-HP	IC 80 bar
	T00267	
3/4"	48-T00234-HP	IC 80 bar
	T00234	
1"	48-T00272-HP	IC 80 bar
	T00272	



OD cutting holder, long

20	48-T00225 T00225
3/4"	48-T00235 T00235

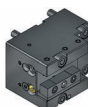

Face cutting holder

25	48-T03024 T03024
3/4"	48-T03018 T03018
1"	48-T03025 T03025



Face cutting holder, HP-IC

20	48-T03017-HP	IC 80 bar
	T03017	
3/4"	48-T03018-HP	IC 80 bar
	T03018	



Cut-off holder, right hand

20	48-T00251 T00251
25	48-T00268 T00268, T00356
3/4"	48-T00252 T00252
1"	48-T00359 T00359, T00357



Boring bar holder

Ø 32	48-T10115 T10115
Ø 1 1/4"	48-T10119 T10119



Combination toolholder

Ø 32	48-T13132	IC 80 bar
	T13132	
Ø 40	48-77999	IC 80 bar
Ø 1 1/4"	48-T13135	IC 80 bar
	T13135	
Ø 1 1/2"	48-80016	IC 80 bar

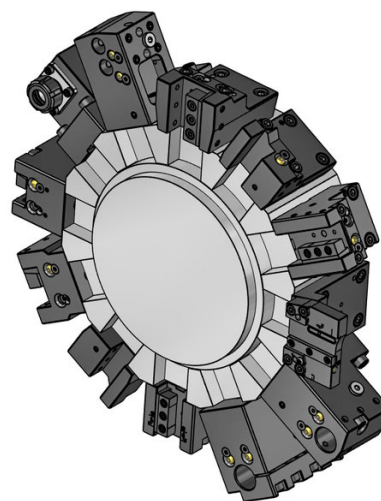
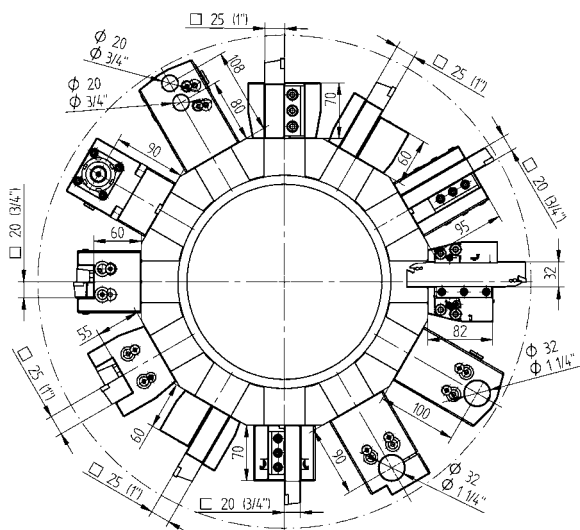

Static Toolholders - Enhanced Program



Cut-off holder, adjustable
SH 32 48-98891



Cut-off holder, adjustable, HP-IC
SH 32 48-102261R IC 80 bar
SH 32 48-102261L IC 80 bar



Boring bar holder, with slot
Ø 32 48-82057
Ø 40 48-82058
Ø 1 1/4" 48-82059
Ø 1 1/2" 48-82060



Boring bar holder, double, universal
Ø 20 48-75406
Ø 3/4" 48-75416



Collet face drill holder
ER 25 48-107230 IC 80 bar
107525000
ER 32 48-81031 IC 80 bar
107532000



VDI adapter, left
VDI 30 48-77732



VDI adapter, right
VDI 30 48-78687



Boring bar holder, blank
48-80506

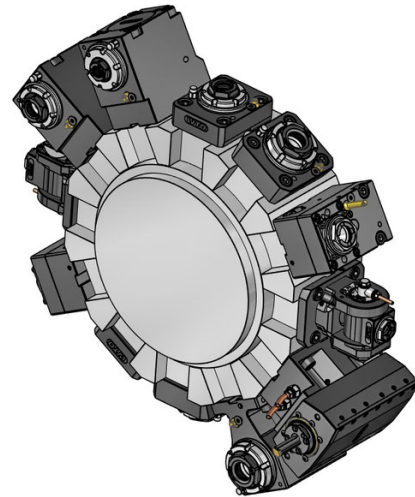
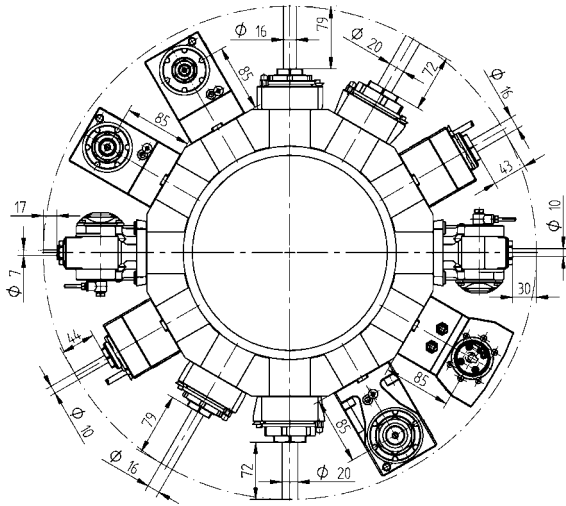

Driven Toolholders - QuickFlex®

Driven Toolholders - QuickFlex®



OD drill/milling unit (12000 RPM)

ER-25 QF	420125012-40 T32433	1:1	EC
	0067725000		
ER-25 QF	420125013-40	1:1	IC 80 bar
	0067725000		
ER-32 QF	420132099-40	1:1	EC
	0067732000		
ER-32 QF	420132100-40	1:1	IC 80 bar
	0067732000		



Face drill/milling unit (6000 RPM, Heavy Duty)

ER-25 QF	420525010-40 T32275, T32297	1:1	EC
	0067725000		
ER-25 QF	420525011-40 T32288, T32435	1:1	IC 80 bar
	0067725000		
ER-32 QF	420532010-40 T32476, T32485	1:1	EC
	0067732000		
ER-32 QF	420532011-40	1:1	IC 80 bar
	0067732000		



OD drill/milling unit (6000 RPM, Heavy Duty)

ER-25 QF	420125010-40 T32274, T32450	1:1	EC
	0067725000		
ER-25 QF	420125011-40 T32287	1:1	IC 80 bar
	0067725000		
ER-32 QF	420132010-40 T32475, T32484	1:1	EC
	0067732000		
ER-32 QF	420132011-40	1:1	IC 80 bar
	0067732000		



Face drill/milling unit (12000 RPM)

ER-25 QF	420525013-40 T32434	1:1	EC
	0067725000		
ER-25 QF	420525014-40 T32436	1:1	IC 80 bar
	0067725000		
ER-32 QF	420532146-40	1:1	EC
	0067732000		
ER-32 QF	420532147-40	1:1	IC 80 bar
	0067732000		

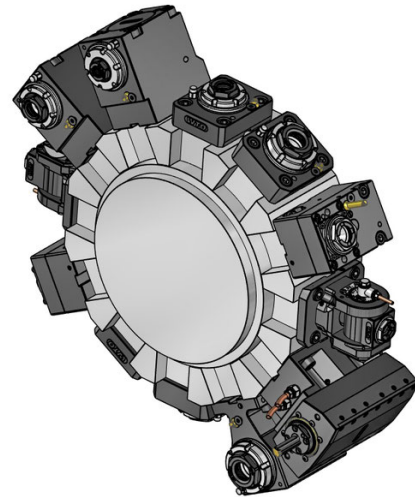
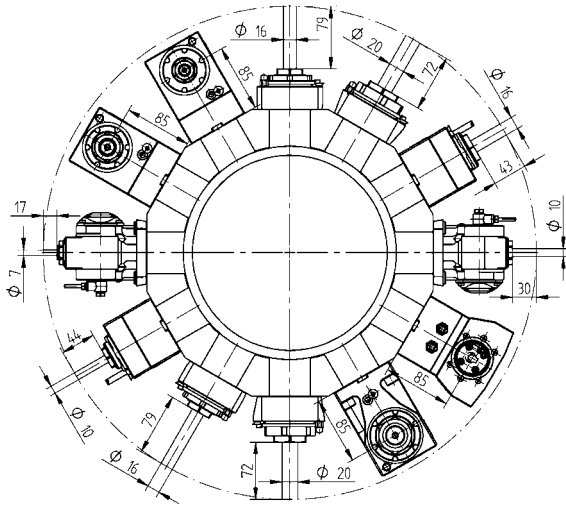

Driven Toolholders - Enhanced Program



OD drill/milling unit, offset

ER 25	410116050-40 T32279, T32488 00675000932	1:1	EC
ER 25	410116057-40 00675000932	1:1	IC 80 bar
ER 20	410113060-40 00675000939	1:2	EC
ER 20	410113068-40 00675000939	1:2	IC 80 bar
ER 16	410410003-40 00675000937	1:3	EC
ER 16	410410004-40 00675000937	1:3	IC 80 bar
ER 25	410116051-40 00675000932	2:1	EC
ER 25	410116058-40 00675000932	2:1	IC 80 bar



OD drill/milling unit, offset (12000 RPM)

ER 25	410116060-40 00675000932	1:1	EC
ER 25	410116059-40 00675000932	1:1	IC 80 bar

Driven Toolholders - Enhanced Program



Face drill/milling unit

ER-20 QF	420520010-40 0067720001	1:2	EC
ER-20 QF	420520011-40 0067720001	1:2	IC 80 bar
ER 16	410810012-40 0067825001	1:3	EC
ER 16	410810013-40 0067825001	1:3	IC 80 bar
ER-32 QF	420532013-40 0067732000	2:1	EC
ER-32 QF	420532014-40 0067732000	2:1	IC 80 bar

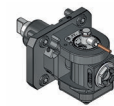

Adjustable angle drill/milling unit

ER 16	411010008-40 00675000913	1:1	EC
ER 16	411010009-40 00675000913	1:1	IC 80 bar
ER 11	411007001-40 00675000914	1:2	EC
ER 11	411007002-40 00675000914	1:2	IC 80 bar



Broaching unit for ID and OD

TN765050	414532000-40	1:1	EC
-----------------	--------------	-----	----

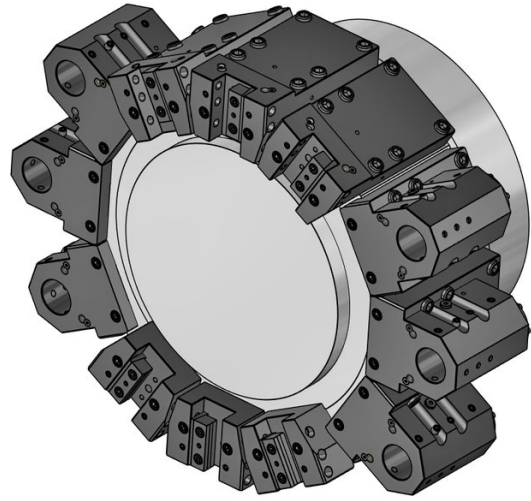
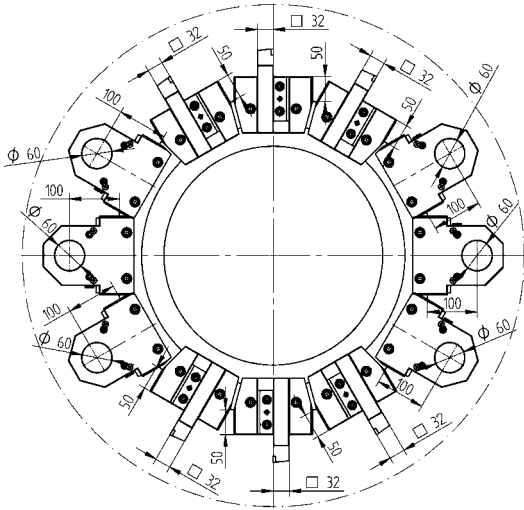

Static Toolholders - Standard Program



OD cutting holder

32 48-T00372
 T00372



Combination toolholder

$\phi 60$ 48-T10168 IC 80 bar
 T10168

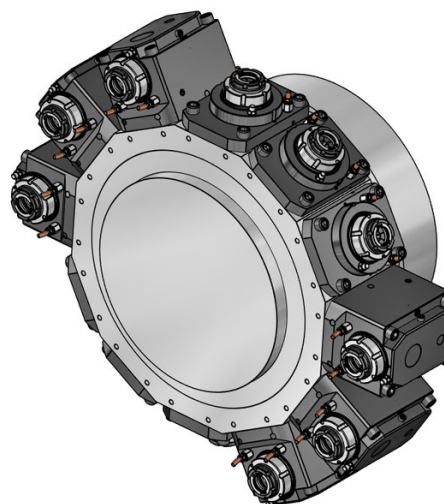
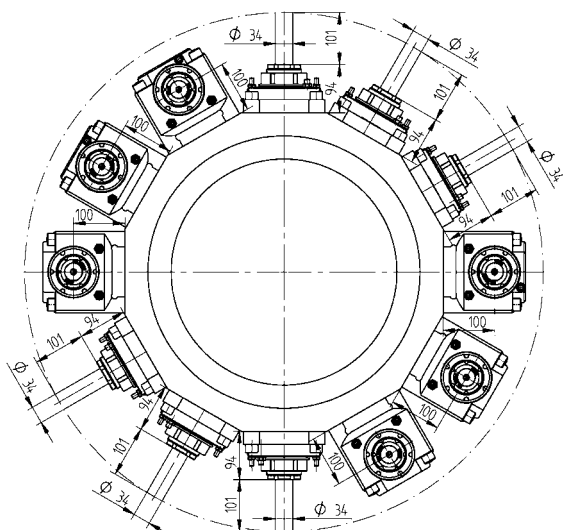

Driven Toolholders - Performance Series



OD drill/milling unit

ER 50 420150000-A1 1:1 EC
T32495

0067550000

ER 50 420150001-A1 1:1 IC 80 bar

0067550000



Face drill/milling unit

ER 50 420550000-A1 1:1 EC
T32496

0067550000

ER 50 420550001-A1 1:1 IC 80 bar

0067550000

Driven Toolholders - QuickFlex®



OD drill/milling unit

ER-50 QF 420150010-A1 1:1 EC
T32495

0067750000

ER-50 QF 420150011-A1 1:1 IC 80 bar

0067750000



Face drill/milling unit

ER-50 QF 420550010-A1 1:1 EC
T32496

0067750000

ER-50 QF 420550011-A1 1:1 IC 80 bar

0067750000

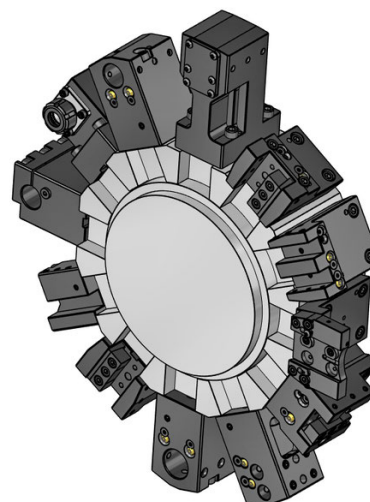
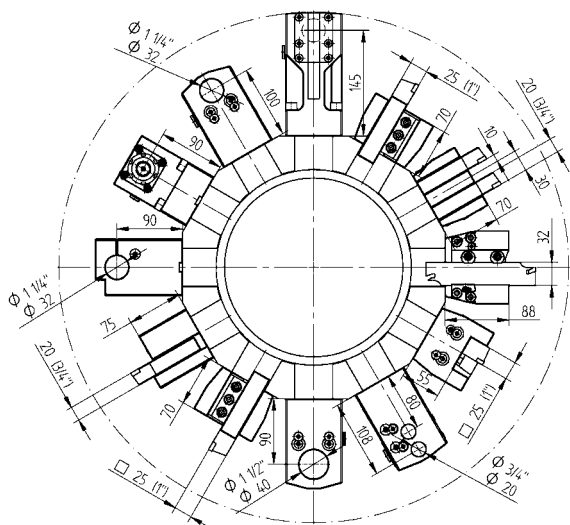

Static Toolholders - Standard Program

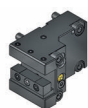

OD cutting holder, short

- | | | |
|-------------|-----------|--------|
| 20 | 48-T00224 | T00224 |
| 25 | 48-T00267 | T00267 |
| 3/4" | 48-T00234 | T00234 |
| 1" | 48-T00272 | T00272 |



OD cutting holder, short, HP-IC

- | | | | |
|-------------|--------------|-----------|--------|
| 20 | 48-T00224-HP | IC 80 bar | T00224 |
| 25 | 48-T00267-HP | IC 80 bar | T00267 |
| 3/4" | 48-T00234-HP | IC 80 bar | T00234 |
| 1" | 48-T00272-HP | IC 80 bar | T00272 |



OD cutting holder, long

- | | | |
|-------------|-----------|--------|
| 20 | 48-T00225 | T00225 |
| 3/4" | 48-T00235 | T00235 |

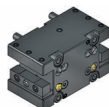

OD cutting holder, both sides, short

- | | | |
|-------------|-----------|--------|
| 20 | 48-T00228 | T00228 |
| 25 | 48-86523 | |
| 3/4" | 48-T00250 | T00250 |
| 1" | 48-86524 | |

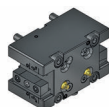

OD cutting holder, both sides, short, HP-IC

- | | | | |
|-------------|--------------|-----------|--------|
| 20 | 48-T00228-HP | IC 80 bar | T00228 |
| 25 | 48-86523-HP | IC 80 bar | |
| 3/4" | 48-T00250-HP | IC 80 bar | T00250 |
| 1" | 48-86524-HP | IC 80 bar | |

Static Toolholders - Standard Program



OD cutting holder, both sides, long

- | | | |
|-------------|-----------|--------|
| 20 | 48-T00226 | T00226 |
| 3/4" | 48-T00249 | T00249 |



Face cutting holder

- | | | |
|-------------|-----------|--------|
| 25 | 48-T03024 | T03024 |
| 3/4" | 48-T03018 | T03018 |
| 1" | 48-T03025 | T03025 |



Face cutting holder, HP-IC

- | | | | |
|-------------|--------------|-----------|--------|
| 20 | 48-T03017-HP | IC 80 bar | T03017 |
| 3/4" | 48-T03018-HP | IC 80 bar | T03018 |



Cut-off holder, right hand

- | | | |
|-------------|-----------|----------------|
| 20 | 48-T00251 | T00251 |
| 25 | 48-T00268 | T00268, T00356 |
| 3/4" | 48-T00252 | T00252 |
| 1" | 48-T00359 | T00359, T00357 |



Combination toolholder

- | | | | |
|-----------------|-----------|-----------|--------|
| Ø 32 | 48-T13132 | IC 80 bar | T13132 |
| Ø 40 | 48-77999 | IC 80 bar | |
| Ø 1 1/4" | 48-T13135 | IC 80 bar | T13135 |
| Ø 1 1/2" | 48-80016 | IC 80 bar | |



Combination toolholder, sub spindle

- | | | | |
|-----------------|-----------|-----------|--------|
| Ø 32 | 48-T10260 | IC 80 bar | T10260 |
| Ø 1 1/4" | 48-T10261 | IC 80 bar | T10261 |

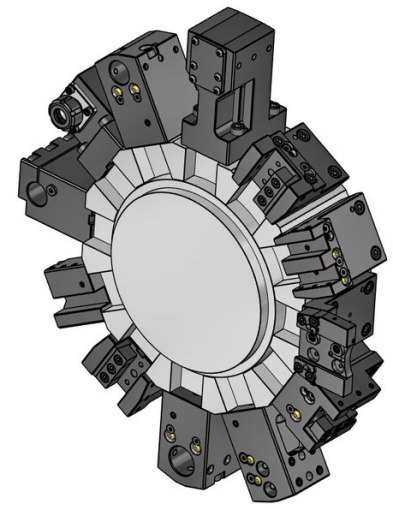
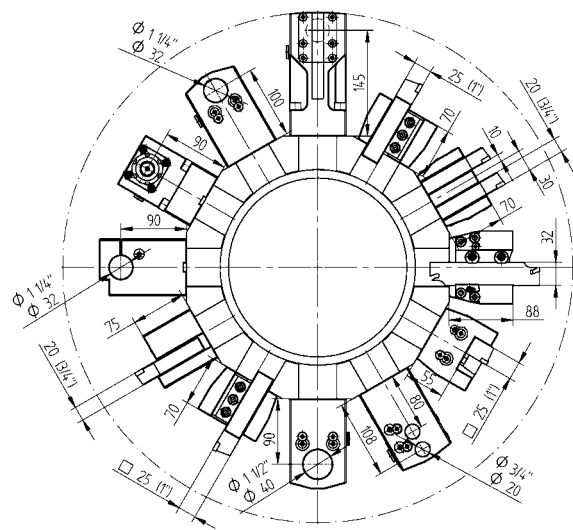



Static Toolholders - Enhanced Program

Static Toolholders - Enhanced Program

- 

OD cutting holder, double, Y axis
 20 (3/4") 48-77726
- 

OD cutting holder, both sides, short, extended
 20 48-79403
 3/4" 48-82167
- 

OD cutting holder, both sides, long, extended
 20 48-81414
 3/4" 48-82168
- 

Cut-off holder, adjustable
 SH 32 48-98891
- 

Cut-off holder, adjustable, HP-IC
 SH 32 48-102261R IC 80 bar
 SH 32 48-102261L IC 80 bar
- 

Boring bar holder, with slot
 Ø 32 48-82057
 Ø 40 48-82058
 Ø 1 1/4" 48-82059
 Ø 1 1/2" 48-82060
- 

Boring bar holder, double, universal
 Ø 20 48-75406
 Ø 3/4" 48-75416
- 

Collet face drill holder
 ER 25 48-107230 IC 80 bar
 107525000
 ER 32 48-81031 IC 80 bar
 107532000

- 

VDI adapter, left
 VDI 30 48-77732
- 

VDI adapter, right
 VDI 30 48-78687
- 

Boring bar holder, blank
 48-80506

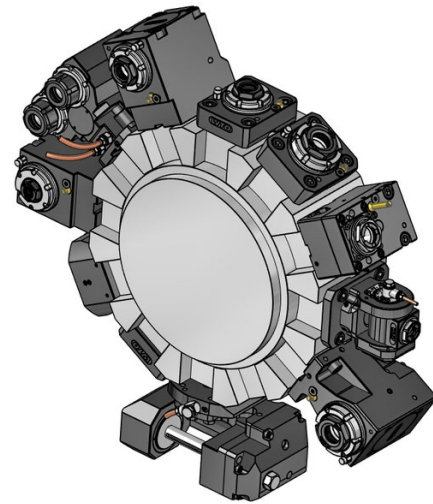
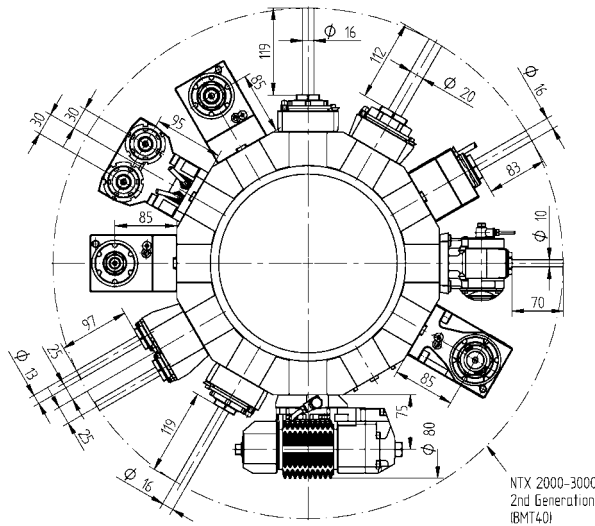

Driven Toolholders - QuickFlex®

Driven Toolholders - QuickFlex®



OD drill/milling unit (12000 RPM)

ER-25 QF	420125012-40 T32433	1:1	EC
	0067725000		
ER-25 QF	420125013-40	1:1	IC 80 bar
	0067725000		
ER-32 QF	420132099-40	1:1	EC
	0067732000		
ER-32 QF	420132100-40	1:1	IC 80 bar
	0067732000		



Face drill/milling unit (6000 RPM, Heavy Duty)

ER-25 QF	420525010-40 T32275, T32297	1:1	EC
	0067725000		
ER-25 QF	420525011-40 T32288, T32435	1:1	IC 80 bar
	0067725000		
ER-32 QF	420532010-40 T32476, T32485	1:1	EC
	0067732000		
ER-32 QF	420532011-40	1:1	IC 80 bar
	0067732000		



OD drill/milling unit (6000 RPM, Heavy Duty)

ER-25 QF	420125010-40 T32274, T32450	1:1	EC
	0067725000		
ER-25 QF	420125011-40 T32287	1:1	IC 80 bar
	0067725000		
ER-32 QF	420132010-40 T32475, T32484	1:1	EC
	0067732000		
ER-32 QF	420132011-40	1:1	IC 80 bar
	0067732000		



Face back set drill/milling unit, sub spindle (only for NTX 1000 S2 2nd Generation)

ER-25 QF	420525047-40	1:1	EC
	0067725010		
ER-25 QF	420525048-40	1:1	IC 80 bar
	0067725010		



Face drill/milling unit (12000 RPM)

ER-25 QF	420525013-40 T32434	1:1	EC
	0067725000		
ER-25 QF	420525014-40 T32436	1:1	IC 80 bar
	0067725000		
ER-32 QF	420532146-40	1:1	EC
	0067732000		
ER-32 QF	420532147-40	1:1	IC 80 bar
	0067732000		

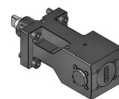

Face drill/milling unit, sub spindle (only for NTX 2000-3000 S2 2nd Generation)

ER-20 QF	420520016-40	1:1	EC
	0067720000		
ER-20 QF	420520017-40	1:1	IC 80 bar
	0067720000		

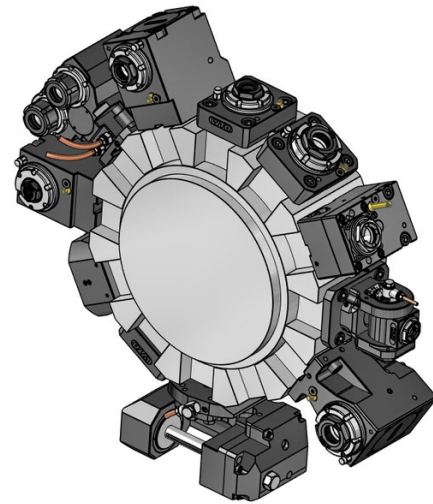
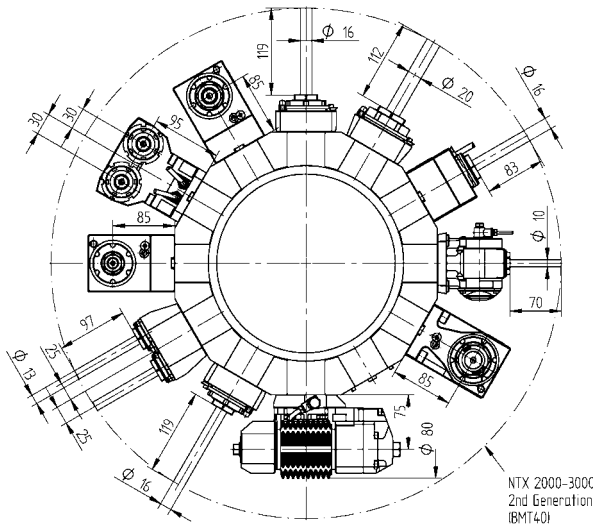

Driven Toolholders - Enhanced Program



**OD milling unit with combination mill arbor
DIN 6358**

Ø 16	410216010-40	1:1	EC
	00675000854		
Ø 22	410222016-40	1:1	EC
	T32280, T32486		
	00675000483		
Ø 3/4"	410219003-40	1:1	EC
	00675000483		



OD drill/milling unit, offset

ER 25	410116050-40	1:1	EC
	T32279, T32488		
	00675000932		
ER 25	410116057-40	1:1	IC 80 bar
	00675000932		
ER 20	410113060-40	1:2	EC
	00675000939		
ER 20	410113068-40	1:2	IC 80 bar
	00675000939		
ER 16	410410003-40	1:3	EC
	00675000937		
ER 16	410410004-40	1:3	IC 80 bar
	00675000937		
ER 25	410116051-40	2:1	EC
	00675000932		
ER 25	410116058-40	2:1	IC 80 bar
	00675000932		



OD drill/milling unit, offset (12000 RPM)

ER 25	410116060-40	1:1	EC
	00675000932		
ER 25	410116059-40	1:1	IC 80 bar
	00675000932		

Driven Toolholders - Enhanced Program



Face drill/milling unit

ER-20 QF	420520010-40	1:2	EC
	0067720001		
ER-20 QF	420520011-40	1:2	IC 80 bar
	0067720001		
ER 16	410810012-40	1:3	EC
	0067825001		
ER 16	410810013-40	1:3	IC 80 bar
	0067825001		
ER-32 QF	420532013-40	2:1	EC
	0067732000		
ER-32 QF	420532014-40	2:1	IC 80 bar
	0067732000		

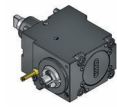

**Face milling unit with combination mill arbor
DIN 6358**

Ø 16	410616013-40	1:1	EC
	00675000854		
Ø 22	410622030-40	1:1	EC
	00675000483		
Ø 22	410622029-40	2:1	EC
	T32292, T32487		
	00675000160		
Ø 3/4"	410619003-40	1:1	EC
	00675000483		
Ø 1"	410625002-40	2:1	EC
	00675000160		

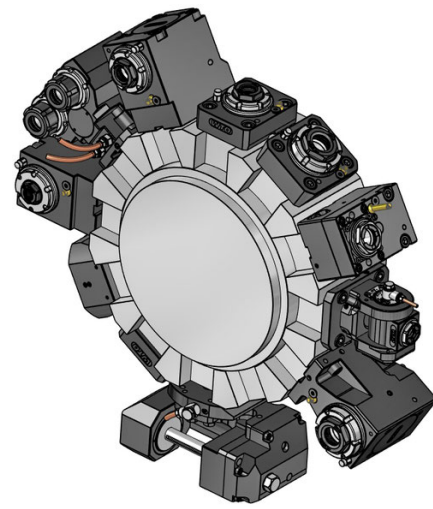
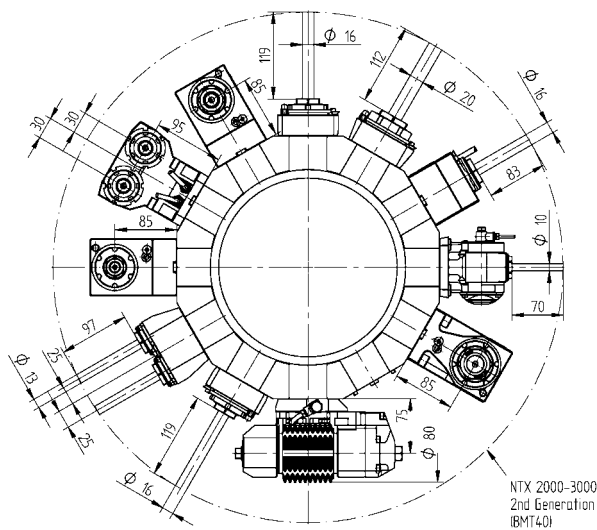

Driven Toolholders - Enhanced Program

Driven Toolholders - Enhanced Program



Adjustable angle drill/milling unit

ER 16	411010008-40	1:1	EC
	00675000913		
ER 16	411010009-40	1:1	IC 80 bar
	00675000913		
ER 11	411007001-40	1:2	EC
	00675000914		
ER 11	411007002-40	1:2	IC 80 bar
	00675000914		

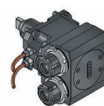

2-spindle - Face drill/milling unit, Y axis

ER 25	413502008-40	1:1	EC
	00675000915		
ER 25	413502009-40	1:1	IC 80 bar
	00675000915		



Gear hobbing unit

Type 16-1	411500017-40	1:1	EC
Type 16-1	411500018-40	2:1	EC
	00675000954		
	160016161 Ø 16		
	160022161 Ø 22		
	160027161 Ø 27		
	160015161 Ø 5/8"		
	160019161 Ø 3/4"		
	160025161 Ø 1"		
	160031161 Ø 1 1/4"		
	110587		



OD drill/milling unit, both sides

ER 20	413002015-40	1:1	EC
	00675000947		
ER 20	413002018-40	1:1	IC 80 bar
	00675000947		



OD drill/milling unit, double, Y axis



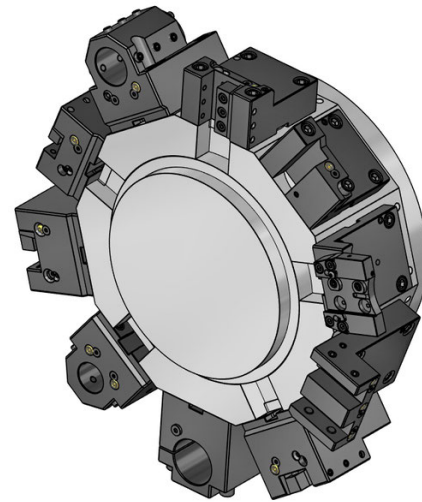
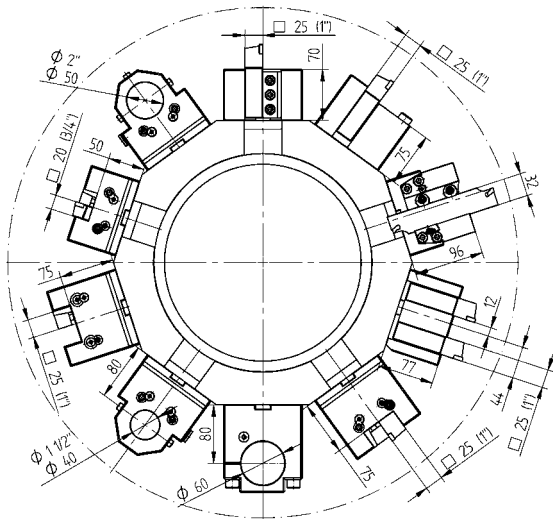

ER 20	413002014-40	1:1	EC
	00675000947		
ER 20	413002017-40	1:1	IC 80 bar
	00675000947		



Static Toolholders - Standard Program

Static Toolholders - Standard Program

	OD cutting holder		
20	48-T00187		
	T00187		
25	48-T00186		
	T00186		
3/4"	48-T00203		
	T00203		
1"	48-T00202		
	T00202		
	OD cutting holder, HP-IC		
25	48-T00186-HP	IC 80 bar	
	T00186		
1"	48-T00202-HP	IC 80 bar	
	T00202		
	OD cutting holder, both sides		
20	48-T00185		
	T00185		
25	48-T00184		
	T00184		
3/4"	48-T00201		
	T00201		
1"	48-T00199		
	T00199		
	OD cutting holder, both sides, HP-IC		
25	48-T00184-HP	IC 80 bar	
	T00184		
1"	48-T00199-HP	IC 80 bar	
	T00199		
	Face cutting holder		
20	48-T03006		
	T03006		
25	48-T03005		
	T03005		
3/4"	48-T03014		
	T03014		
1"	48-T03013		
	T03013		

	Face cutting holder, HP-IC		
25	48-T03005-HP	IC 80 bar	
	T03005		
1"	48-T03013-HP	IC 80 bar	
	T03013		
	Cut-off holder, right hand		
25	48-T00197		
	T00197		
1"	48-T00198		
	T00198		
	Boring bar holder, LF=80		
Ø 40	48-T10097		
	T10097		
Ø 50	48-T10098		
	T10098		
Ø 1 1/2"	48-T10101		
	T10101		
Ø 2"	48-T10102		
	T10102		
Ø 2 1/2"	48-70080		
	Combination toolholder, LF=80		
Ø 40	48-T13128	IC 80 bar	
	T13128		
Ø 50	48-T13139	IC 80 bar	
	T13139		
Ø 1 1/2"	48-T13130	IC 80 bar	
	T13130		
Ø 2"	48-T13140	IC 80 bar	
	T13140		

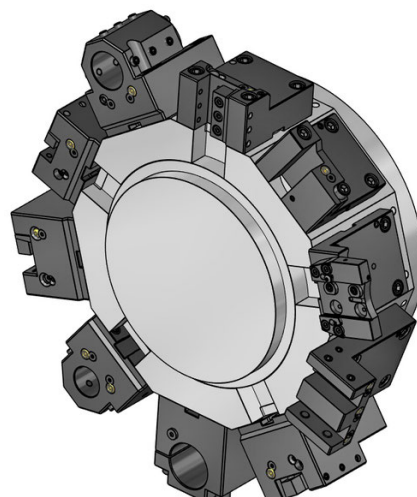
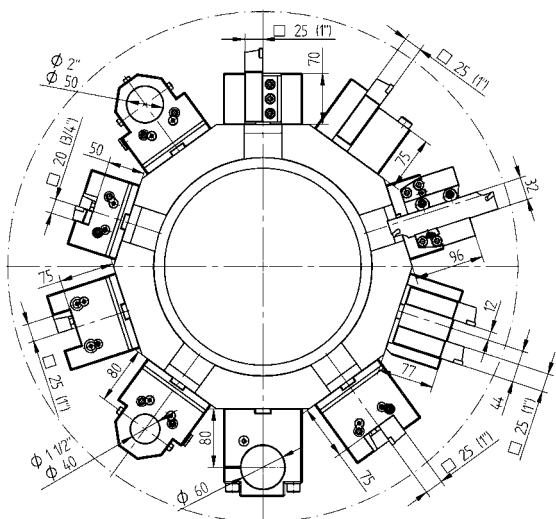

Static Toolholders - Enhanced Program

Static Toolholders - Enhanced Program

- 

OD cutting holder, right hand, long, HP-IC

25	48-T00385-HP	IC 80 bar
	T00385	
1"	48-T00386-HP	IC 80 bar
	T00386	
- 

OD cutting holder, left hand, long, HP-IC

25	48-T00387-HP	IC 80 bar
	T00387	
1"	48-T00388-HP	IC 80 bar
	T00388	
- 

OD cutting holder, double, Y axis

25(1")	48-71865	
	T00206, T00210	
- 

OD cutting holder, both sides, double, Y axis

25(1")	48-71863	
	T00253, T00258	
- 

Cut-off holder, adjustable

SH 32	48-98901	
--------------	----------	--
- 

Cut-off holder, adjustable, HP-IC

SH 32	48-102262R	IC 80 bar
SH 32	48-102262L	IC 80 bar
- 

Cut-off holder, adjustable, extended

SH 32	48-77478	
--------------	----------	--

- 

Boring bar holder, with slot

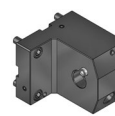
Ø 40	48-T10136
	T10136
Ø 50	48-T10137
	T10137
Ø 60	48-70811
Ø 1 1/2"	48-T10143
	T10143
Ø 2"	48-T10142
	T10142
- 

VDI adapter, left

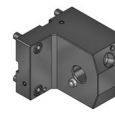
VDI 30	48-77127
VDI 40	48-72984
- 

VDI adapter, right

VDI 30	48-74796
VDI 40	48-77955
- 

Boring bar holder, blank

48-81080

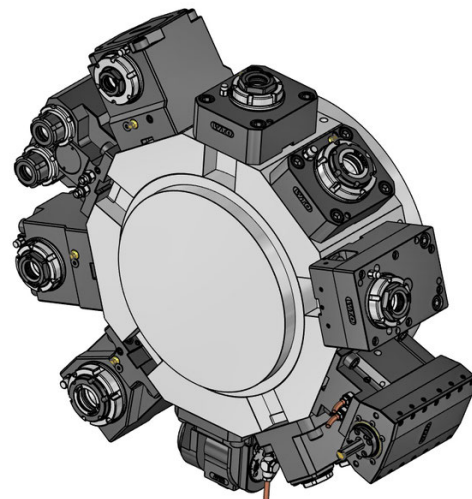
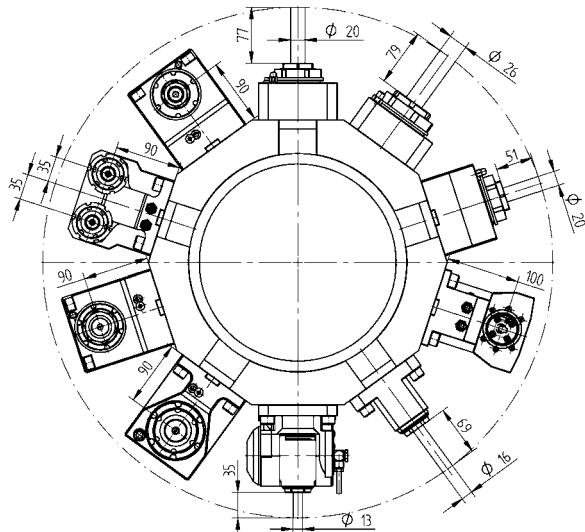

Driven Toolholders - QuickFlex®

Driven Toolholders - Enhanced Program



OD drill/milling unit (6000 RPM, Heavy Duty)

ER-32 QF	420132010-60 T32206, T32249	1:1	EC
	0067732000		
ER-32 QF	420132011-60 T32232, T32478	1:1	IC 80 bar
	0067732000		
ER-40 QF	420140010-60 T32213	1:1	EC
	0067740000		
ER-40 QF	420140011-60 T32234	1:1	IC 80 bar
	0067740000		



Face drill/milling unit (6000 RPM, Heavy Duty)

ER-32 QF	420532010-60 T32207, T32256	1:1	EC
	0067732000		
ER-32 QF	420532011-60 T32233	1:1	IC 80 bar
	0067732000		
ER-40 QF	420540012-60 T32214	1:1	EC
	0067740000		
ER-40 QF	420540013-60 T32235	1:1	IC 80 bar
	0067740000		



**OD milling unit with combination mill arbor
DIN 6358**

Ø 16	410216000-60	1:1	EC
	00675000854		
Ø 22	410222007-60	1:1	EC
	T32268		
	00675000483		
Ø 27	410227008-60	1:1	EC
	00675000245		
Ø 3/4"	410219000-60	1:1	EC
	00675000483		
Ø 1"	410225000-60	1:1	EC
	T32217		
	00675000483		



OD drill/milling unit, offset

ER-32 QF	420132019-60	1:1	EC
	0067732000		
ER-32 QF	420132020-60	1:1	IC 80 bar
	0067732000		
ER-25 QF	420125010-60	1:2	EC
	0067725001		
ER-25 QF	420125011-60	1:2	IC 80 bar
	0067725001		
ER-32 QF	420132021-60	2:1	EC
	0067732000		
ER-32 QF	420132022-60	2:1	IC 80 bar
	0067732000		

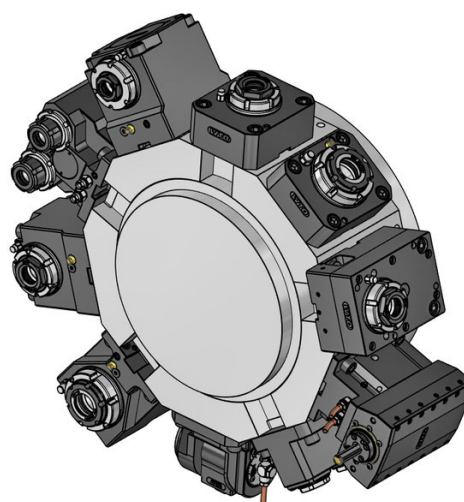
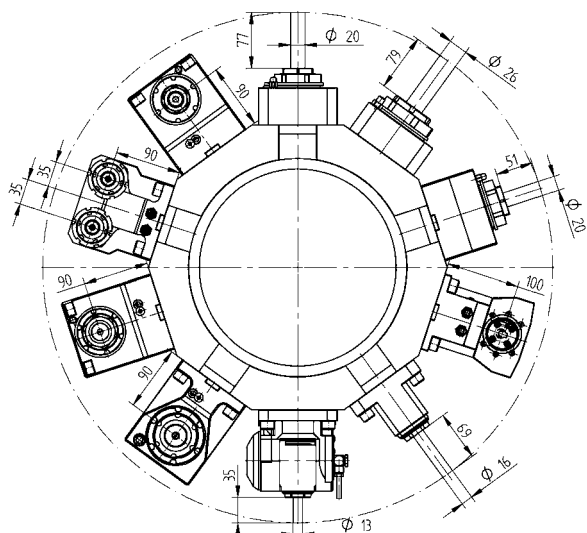

Driven Toolholders - Enhanced Program

Driven Toolholders - Enhanced Program



Face drill/milling unit

ER-25 QF	420525010-60	1:2	EC
	0067725001		
ER-25 QF	420525011-60	1:2	IC 80 bar
	0067725001		
ER-40 QF	420540014-60	2:1	EC
	0067740000		
ER-40 QF	420540015-60	2:1	IC 80 bar
	0067740000		



Face milling unit with combination mill arbor DIN 6358

Ø 22	410622000-60	2:1	EC
	T32269		
	00675000483		
Ø 27	410627000-60	2:1	EC
	00675000245		
Ø 1"	410625000-60	2:1	EC
	T32226		
	00675000483		



Adjustable angle drill/milling unit

ER 20	411013009-60	1:1	EC
	T32474		
	00675000928		
ER 20	411013010-60	1:1	IC 80 bar
	00675000928		
ER 16	411010001-60	1:2	EC
	00675000936		
ER 16	411010002-60	1:2	IC 80 bar
	00675000936		



OD drill/milling unit, both sides

ER 25	413002001-60	1:1	EC
	00675000907		



OD drill/milling unit, double, Y axis

ER 25	413002000-60	1:1	EC
	T32267		
	00675000907		

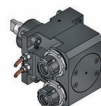

2-spindle - Face drill/milling unit, Y axis

ER 25	413502000-60	1:1	EC
	T32264		
	00675000915		
ER 25	413502002-60	1:1	IC 80 bar
	00675000915		

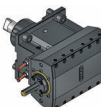

Broaching unit for ID and OD

TN765050	414532000-60	1:1	EC
-----------------	--------------	-----	----

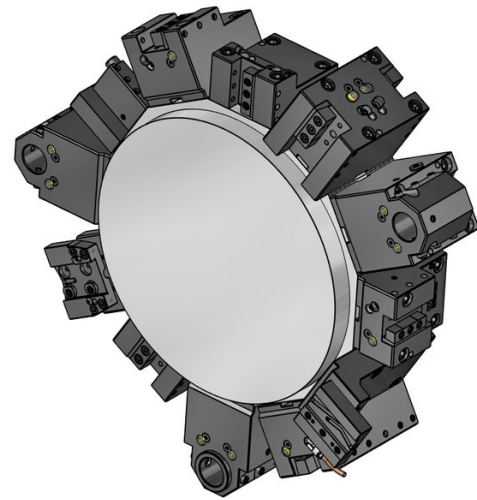
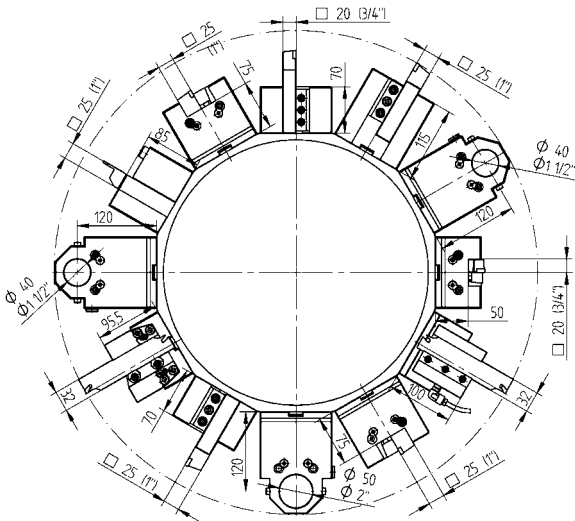

Static Toolholders - Standard Program

Static Toolholders - Standard Program

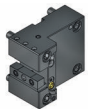

OD cutting holder

- 20** 48-T00187
T00187
- 25** 48-T00186
T00186
- 3/4"** 48-T00203
T00203
- 1"** 48-T00202
T00202



OD cutting holder, HP-IC

- 25** 48-T00186-HP IC 80 bar
T00186
- 1"** 48-T00202-HP IC 80 bar
T00202



OD cutting holder, both sides

- 20** 48-T00185
T00185
- 25** 48-T00184
T00184
- 3/4"** 48-T00201
T00201
- 1"** 48-T00199
T00199



OD cutting holder, both sides, HP-IC

- 25** 48-T00184-HP IC 80 bar
T00184
- 1"** 48-T00199-HP IC 80 bar
T00199



OD cutting holder, both sides, long

- 25** 48-T00237
T00237
- 1"** 48-78257

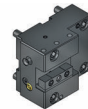

Face cutting holder

- 20** 48-T03006
T03006
- 25** 48-T03005
T03005
- 3/4"** 48-T03014
T03014
- 1"** 48-T03013
T03013



Face cutting holder, HP-IC

- 25** 48-T03005-HP IC 80 bar
T03005
- 1"** 48-T03013-HP IC 80 bar
T03013



Cut-off holder, right hand

- 25** 48-T00197
T00197
- 1"** 48-T00198
T00198



Boring bar holder, LF=120

- Ø 40** 48-T10113
T10113
- Ø 50** 48-T10114
T10114
- Ø 1 1/2"** 48-T10134
T10134
- Ø 2"** 48-T10135
T10135



Combination toolholder, LF=120

- Ø 40** 48-T13131 IC 80 bar
T13131
- Ø 50** 48-77902 IC 80 bar
- Ø 1 1/2"** 48-T13137 IC 80 bar
T13137
- Ø 2"** 48-77901 IC 80 bar

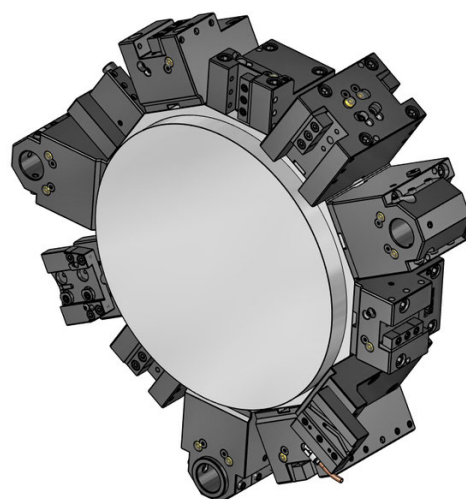
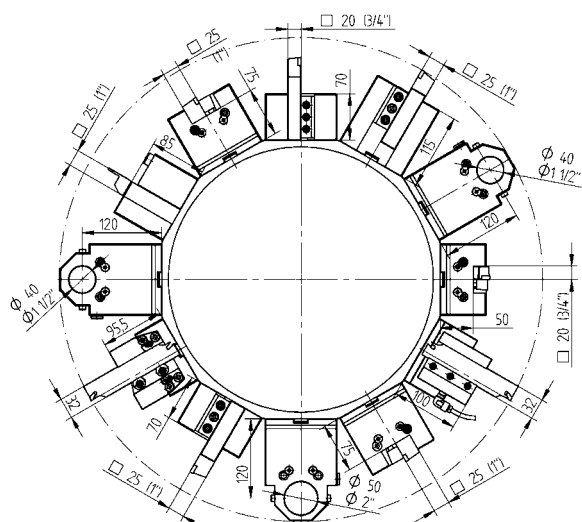

Static Toolholders - Enhanced Program

Static Toolholders - Enhanced Program

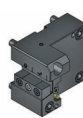
- 

OD cutting holder, right hand, long, HP-IC

25	48-T00385-HP	IC 80 bar
	T00385	
1"	48-T00386-HP	IC 80 bar
	T00386	
- 

OD cutting holder, left hand, long, HP-IC

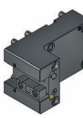
25	48-T00387-HP	IC 80 bar
	T00387	
1"	48-T00388-HP	IC 80 bar
	T00388	
- 

OD cutting holder, extended

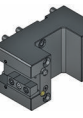
25	48-76267	
1"	48-81553	
- 

OD cutting holder, both sides, extended

25	48-81627	
1"	48-82499	
- 

Face cutting holder, both sides

25	48-78995	
1"	48-78996	
- 

Cut-off holder, adjustable

SH 32	48-98901	
-------	----------	--
- 

Cut-off holder, adjustable, HP-IC



SH 32	48-102262R	IC 80 bar
SH 32	48-102262L	IC 80 bar
- 

Cut-off holder, adjustable, extended

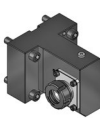

SH 32	48-77478	
-------	----------	--

- 

Collet face drill holder

ER 32	48-94564	IC 80 bar
	 107532000	
ER 40	48-94566	IC 80 bar
	 107540000	
- 

Collet face drill holder, both sides

ER 32	48-94565	IC 80 bar
	 107532000	
ER 40	48-94567	IC 80 bar
	 107540000	
- 

VDI adapter, left

VDI 30	48-77127	
VDI 40	48-72984	
- 

VDI adapter, right

VDI 30	48-74796	
VDI 40	48-77955	
- 

Boring bar holder, blank

48-81081		
----------	--	--

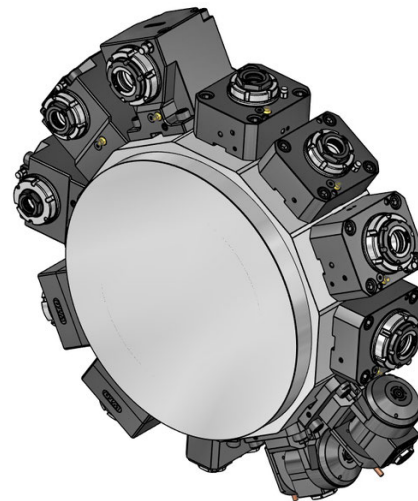
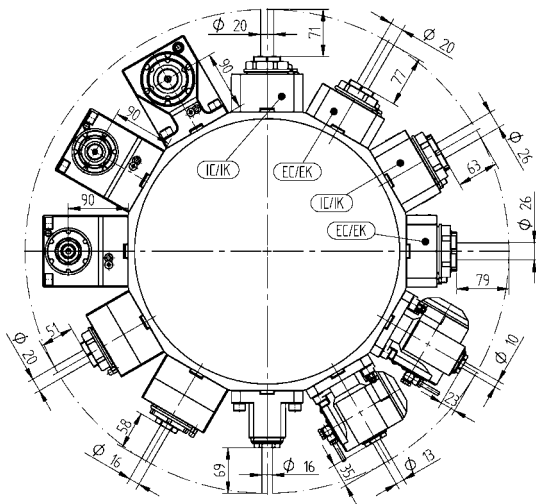

Driven Toolholders - QuickFlex®

Driven Toolholders - Enhanced Program



OD drill/milling unit (6000 RPM, Heavy Duty)

ER-32 QF	420132010-60 T32206, T32249	1:1	EC
	0067732000		
ER-32 QF	420132011-60 T32232, T32478	1:1	IC 80 bar
	0067732000		
ER-40 QF	420140010-60 T32213	1:1	EC
	0067740000		
ER-40 QF	420140011-60 T32234	1:1	IC 80 bar
	0067740000		



**OD milling unit with combination mill arbor
DIN 6358**

Ø 16	410216000-60	1:1	EC
	00675000854		
Ø 22	410222007-60 T32268	1:1	EC
	00675000483		
Ø 27	410227008-60	1:1	EC
	00675000245		
Ø 3/4"	410219000-60	1:1	EC
	00675000483		
Ø 1"	410225000-60 T32217	1:1	EC
	00675000483		



Face drill/milling unit (6000 RPM, Heavy Duty)

ER-32 QF	420532010-60 T32207, T32256	1:1	EC
	0067732000		
ER-32 QF	420532011-60 T32233	1:1	IC 80 bar
	0067732000		
ER-40 QF	420540012-60 T32214	1:1	EC
	0067740000		
ER-40 QF	420540013-60 T32235	1:1	IC 80 bar
	0067740000		



OD drill/milling unit, offset

ER-32 QF	420132019-60	1:1	EC
	0067732000		
ER-32 QF	420132020-60	1:1	IC 80 bar
	0067732000		
ER-25 QF	420125010-60	1:2	EC
	0067725001		
ER-25 QF	420125011-60	1:2	IC 80 bar
	0067725001		
ER-32 QF	420132021-60	2:1	EC
	0067732000		
ER-32 QF	420132022-60	2:1	IC 80 bar
	0067732000		



Face drill/milling unit, both sides (6000 RPM, Heavy Duty)

ER-32 QF	420532019-60 T32216	1:1	EC
	0067732000		
ER-40 QF	420540016-60 T32248	1:1	EC
	0067740000		

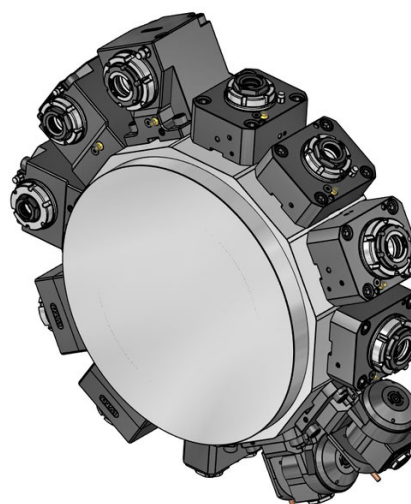
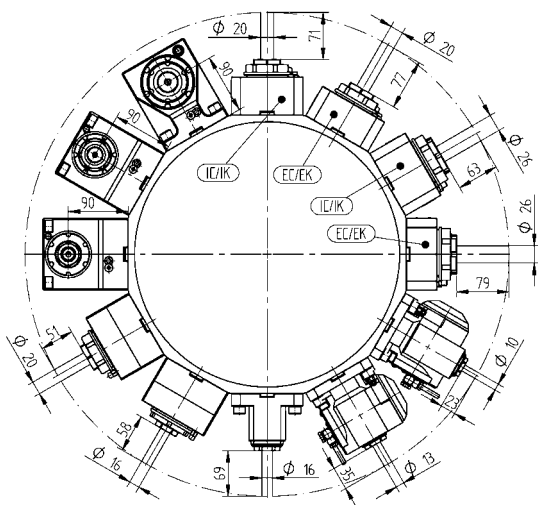

Driven Toolholders - Enhanced Program



Face drill/milling unit

ER-25 QF	420525010-60	1:2	EC
	0067725001		
ER-25 QF	420525011-60	1:2	IC 80 bar
	0067725001		
ER-40 QF	420540014-60	2:1	EC
	0067740000		
ER-40 QF	420540015-60	2:1	IC 80 bar
	0067740000		



**Face milling unit with combination mill arbor
DIN 6358**

Ø 22	410622000-60	2:1	EC
	T32269		
	00675000483		
Ø 27	410627000-60	2:1	EC
	00675000245		
Ø 1"	410625000-60	2:1	EC
	T32226		
	00675000483		



Adjustable angle drill/milling unit

ER 20	411013009-60	1:1	EC
	T32474		
	00675000928		
ER 20	411013010-60	1:1	IC 80 bar
	00675000928		
ER 16	411010001-60	1:2	EC
	00675000936		
ER 16	411010002-60	1:2	IC 80 bar
	00675000936		



OD drill/milling unit, both sides

ER 25	413002001-60	1:1	EC
	00675000907		

Standard reduction sleeves - cylindrical



Reduction sleeve Ø 20

240020006	ø 6
240020008	ø 8
240020010	ø 10
240020012	ø 12
240020014	ø 14
240020016	ø 16



Reduction sleeve Ø 25

240025006	ø 6
240025008	ø 8
240025010	ø 10
240025012	ø 12
240025014	ø 14
240025016	ø 16
240025020	ø 20



Reduction sleeve Ø 32

240032006	ø 6
240032008	ø 8
240032010	ø 10
240032012	ø 12
240032014	ø 14
240032016	ø 16
240032018	ø 18
240032020	ø 20
240032025	ø 25



Reduction sleeve Ø 40

240040006	ø 6
240040008	ø 8
240040010	ø 10
240040012	ø 12
240040014	ø 14
240040016	ø 16
240040020	ø 20
240040025	ø 25
240040032	ø 32



Reduction sleeve Ø 50

240050010	ø 10
240050012	ø 12
240050016	ø 16
240050020	ø 20
240050025	ø 25
240050025	ø 25
240050032	ø 32
240050040	ø 40

Standard reduction sleeves - cylindrical



Reduction sleeve Ø 3/4"

2400075025	ø 1/4"
2400075032	ø 5/16"
2400075038	ø 3/8"
2400075050	ø 1/2"
2400075063	ø 5/8"



Reduction sleeve Ø 1"

2400100025	ø 1/4"
2400100031	ø 5/16"
2400100038	ø 3/8"
2400100050	ø 1/2"
2400100063	ø 5/8"
2400100075	ø 3/4"



Reduction sleeve Ø 1 1/4"

2400125038	ø 3/8"
2400125050	ø 1/2"
2400125063	ø 5/8"
2400125075	ø 3/4"
2400125088	ø 7/8"
2400125100	ø 1"



Reduction sleeve Ø 1 1/2"

2400150038	ø 3/8"
2400150050	ø 1/2"
2400150063	ø 5/8"
2400150075	ø 3/4"
2400150088	ø 7/8"
2400150100	ø 1"
2400150125	ø 1 1/4"



Reduction sleeve Ø 2"

2400200050	ø 1/2"
2400200063	ø 5/8"
2400200088	ø 7/8"
2400200100	ø 1"
2400200125	ø 1 1/4"
2400200150	ø 1 1/2"
2400200175	ø 1 3/4"

Standard reduction sleeves - cylindrical, with slot



Reduction sleeve Ø 32

240132008	ø 8
240132010	ø 10
240132012	ø 12
240132015	ø 15
240132016	ø 16
240132020	ø 20
240132025	ø 25

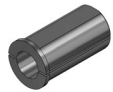

Reduction sleeve Ø 40

240140010	ø 10
240140012	ø 12
240140015	ø 15
240140016	ø 16
240140020	ø 20
240140025	ø 25
240140032	ø 32

Standard reduction sleeves - morse taper



Reduction sleeve Ø 32

240532001	MT 1
240532002	MT 2
240532003	MT 3



Reduction sleeve Ø 40

240540001	MT 1
240540002	MT 2
240540003	MT 3
240540004	MT 4

Reduction sleeves for boring bar holders - cylindrical

Reduction sleeves for boring bar holders - cylindrical



Reduction sleeve Ø 25

24-T20180	ø 8
24-T20182	ø 10
24-T20184	ø 12
24-T20186	ø 16
24-T20188	ø 20



Reduction sleeve Ø 1 1/2"

24-T20089	ø 3/8"
24-T20091	ø 1/2"
24-T20093	ø 5/8"
24-T20095	ø 3/4"
24-T20097	ø 1"
24-T20099	ø 1 1/4"



Reduction sleeve Ø 32

24-T20112	ø 8
24-T20114	ø 10
24-T20116	ø 12
24-T20118	ø 16
24-T20120	ø 20
24-T20122	ø 25



Reduction sleeve Ø 2"

24-T20163	ø 1/2"
24-T20165	ø 5/8"
24-T20167	ø 3/4"
24-T20169	ø 1"
24-T20171	ø 1 1/4"
24-T20173	ø 1 1/2"



Reduction sleeve Ø 40

24-T20086	ø 8
24-T20088	ø 10
24-T20090	ø 12
24-T20092	ø 16
24-T20094	ø 20
24-T20096	ø 25
24-T20098	ø 32



Reduction sleeve Ø 50

24-T20160	ø 10
24-T20162	ø 12
24-T20164	ø 16
24-T20166	ø 20
24-T20168	ø 25
24-T20170	ø 32
24-T20172	ø 40



Reduction sleeve Ø 60

24-T20136	ø 32
24-T20138	ø 40
24-T20140	ø 50



Reduction sleeve Ø 1"

24-T20181	ø 3/8"
24-T20183	ø 1/2"
24-T20185	ø 5/8"
24-T20187	ø 3/4"



Reduction sleeve Ø 1 1/4"

24-T20115	ø 3/8"
24-T20117	ø 1/2"
24-T20119	ø 5/8"
24-T20121	ø 3/4"
24-T20123	ø 1"

Reduction sleeves for boring bar holders - cylindrical, extended



Reduction sleeve Ø 32

24-T20124	ø 8
24-T20126	ø 10
24-T20128	ø 12
24-T20130	ø 16



Reduction sleeve Ø 40

24-T20106	ø 8
24-T20108	ø 10
24-T20110	ø 12
24-T20194	ø 16
24-T20196	ø 20
24-T20216	ø 25



Reduction sleeve Ø 1 1/4"

24-T20127	ø 3/8"
24-T20129	ø 1/2"
24-T20131	ø 5/8"



Reduction sleeve Ø 1 1/2"

24-T20109	ø 3/8"
24-T20111	ø 1/2"
24-T20195	ø 5/8"
24-T20197	ø 3/4"

Reduction sleeves for boring bar holders - morse taper

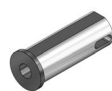

Reduction sleeve Ø 40

24-T22046	MT 2
24-T22042	MT 3



Reduction sleeve Ø 50

24-T22044	MT 4
-----------	------

Collets DIN 6499B (ER/ESX)



ER 11	mm	inch
190011000	∅ 7-0.5	∅ 0.276-0.020
190011010	∅ 1-0.5	∅ 0.039-0.020
190011015	∅ 1.5-1	∅ 0.059-0.039
190011020	∅ 2-1.5	∅ 0.079-0.059
190011025	∅ 2.5-2	∅ 0.098-0.079
190011030	∅ 3-2.5	∅ 0.118-0.098
190011035	∅ 3.5-3	∅ 0.138-0.118
190011040	∅ 4-3.5	∅ 0.158-0.138
190011045	∅ 4.5-4	∅ 0.177-0.158
190011050	∅ 5-4.5	∅ 0.197-0.177
190011055	∅ 5.5-5	∅ 0.217-0.197
190011060	∅ 6-5.5	∅ 0.236-0.217
190011065	∅ 6.5-6	∅ 0.256-0.236
190011070	∅ 7-6.5	∅ 0.276-0.256



ER 16	mm	inch
190016000	∅ 10-0.5	∅ 0.394-0.020
190016010	∅ 1-0.5	∅ 0.039-0.020
190016020	∅ 2-1	∅ 0.079-0.039
190016030	∅ 3-2	∅ 0.118-0.079
190016040	∅ 4-3	∅ 0.158-0.118
190016050	∅ 5-4	∅ 0.197-0.158
190016060	∅ 6-5	∅ 0.236-0.197
190016070	∅ 7-6	∅ 0.276-0.236
190016080	∅ 8-7	∅ 0.315-0.276
190016090	∅ 9-8	∅ 0.354-0.315
190016100	∅ 10-9	∅ 0.394-0.354



ER 20	mm	inch
190020000	∅ 13-1	∅ 0.512-0.039
190020010	∅ 1-0.5	∅ 0.039-0.020
190020020	∅ 2-1	∅ 0.079-0.039
190020030	∅ 3-2	∅ 0.118-0.079
190020040	∅ 4-3	∅ 0.157-0.118
190020050	∅ 5-4	∅ 0.197-0.157
190020060	∅ 6-5	∅ 0.236-0.197
190020070	∅ 7-6	∅ 0.276-0.236
190020080	∅ 8-7	∅ 0.315-0.276
190020090	∅ 9-8	∅ 0.354-0.315
190020100	∅ 10-9	∅ 0.394-0.354
190020110	∅ 11-10	∅ 0.433-0.394
190020120	∅ 12-11	∅ 0.472-0.433
190020130	∅ 13-12	∅ 0.512-0.472

Collets DIN 6499B (ER/ESX)



ER 25	mm	inch
190025000	∅ 16-1	∅ 0.630-0.039
190025020	∅ 2-1	∅ 0.079-0.039
190025030	∅ 3-2	∅ 0.118-0.079
190025040	∅ 4-3	∅ 0.157-0.118
190025050	∅ 5-4	∅ 0.197-0.157
190025060	∅ 6-5	∅ 0.236-0.197
190025070	∅ 7-6	∅ 0.276-0.236
190025080	∅ 8-7	∅ 0.315-0.276
190025090	∅ 9-8	∅ 0.354-0.315
190025100	∅ 10-9	∅ 0.394-0.354
190025110	∅ 11-10	∅ 0.433-0.394
190025120	∅ 12-11	∅ 0.472-0.433
190025130	∅ 13-12	∅ 0.512-0.472
190025140	∅ 14-13	∅ 0.551-0.512
190025150	∅ 15-14	∅ 0.591-0.551
190025160	∅ 16-15	∅ 0.630-0.591



ER 32	mm	inch
190032000	∅ 20-2	∅ 0.787-0.079
190032030	∅ 3-2	∅ 0.118-0.079
190032040	∅ 4-3	∅ 0.157-0.118
190032050	∅ 5-4	∅ 0.197-0.157
190032060	∅ 6-5	∅ 0.236-0.197
190032070	∅ 7-6	∅ 0.276-0.236
190032080	∅ 8-7	∅ 0.315-0.276
190032090	∅ 9-8	∅ 0.354-0.315
190032100	∅ 10-9	∅ 0.394-0.354
190032110	∅ 11-10	∅ 0.433-0.394
190032120	∅ 12-11	∅ 0.472-0.433
190032130	∅ 13-12	∅ 0.512-0.472
190032140	∅ 14-13	∅ 0.551-0.512
190032150	∅ 15-14	∅ 0.591-0.551
190032160	∅ 16-15	∅ 0.630-0.591
190032170	∅ 17-16	∅ 0.669-0.630
190032180	∅ 18-17	∅ 0.709-0.669
190032190	∅ 19-18	∅ 0.748-0.709
190032200	∅ 20-19	∅ 0.787-0.748

Collets DIN 6499B (ER/ESX)



ER 40	mm	inch
190040000	∅ 26-3	∅ 1.024-0.118
190040040	∅ 4-3	∅ 0.157-0.118
190040050	∅ 5-4	∅ 0.197-0.157
190040060	∅ 6-5	∅ 0.236-0.197
190040070	∅ 7-6	∅ 0.276-0.236
190040080	∅ 8-7	∅ 0.315-0.276
190040090	∅ 9-8	∅ 0.354-0.315
190040100	∅ 10-9	∅ 0.394-0.354
190040110	∅ 11-10	∅ 0.433-0.394
190040120	∅ 12-11	∅ 0.472-0.433
190040130	∅ 13-12	∅ 0.512-0.472
190040140	∅ 14-13	∅ 0.551-0.512
190040150	∅ 15-14	∅ 0.591-0.551
190040160	∅ 16-15	∅ 0.630-0.591
190040170	∅ 17-16	∅ 0.669-0.630
190040180	∅ 18-17	∅ 0.709-0.669
190040190	∅ 19-18	∅ 0.748-0.709
190040200	∅ 20-19	∅ 0.787-0.748
190040210	∅ 21-20	∅ 0.827-0.787
190040220	∅ 22-21	∅ 0.866-0.827
190040230	∅ 23-22	∅ 0.906-0.866
190040240	∅ 24-23	∅ 0.945-0.906
190040250	∅ 25-24	∅ 0.984-0.945
190040260	∅ 26-25	∅ 1.024-0.984



ER 50	mm	inch
190050000	∅ 34-10	∅ 1.339-0.394
190050060	∅ 6-4	∅ 0.236-0.157
190050080	∅ 8-6	∅ 0.315-0.236
190050100	∅ 10-8	∅ 0.394-0.315
190050120	∅ 12-10	∅ 0.472-0.394
190050140	∅ 14-12	∅ 0.551-0.472
190050160	∅ 16-14	∅ 0.630-0.551
190050180	∅ 18-16	∅ 0.709-0.630
190050200	∅ 20-18	∅ 0.787-0.709
190050220	∅ 22-20	∅ 0.866-0.787
190050240	∅ 24-22	∅ 0.945-0.866
190050260	∅ 26-24	∅ 1.024-0.945
190050280	∅ 28-26	∅ 1.102-1.024
190050300	∅ 30-28	∅ 1.181-1.102
190050320	∅ 32-30	∅ 1.260-1.181
190050340	∅ 34-32	∅ 1.339-1.260

Collets DIN 6499D (ER/ESX) - sealed, for IC



ER 11	mm	inch
191011030	∅ 3	
191011040	∅ 4	
191011050	∅ 5	
191011060	∅ 6	
191111013-in		∅ 0.125
191111019-in		∅ 0.188
191111025-in		∅ 0.25



ER 16	mm	inch
191016000	∅ 3-10	
191016030	∅ 3	
191016040	∅ 4	
191016050	∅ 5	
191016060	∅ 6	
191016070	∅ 7	
191016080	∅ 8	
191016090	∅ 9	
191016100	∅ 10	
191116001		∅ 0.125-0.375
191116013-in		∅ 0.125
191116019-in		∅ 0.188
191116025-in		∅ 0.25
191116031-in		∅ 0.313
191116038-in		∅ 0.375



ER 20	mm	inch
191020000	∅ 3-12	
191020030	∅ 3	
191020040	∅ 4	
191020050	∅ 5	
191020060	∅ 6	
191020070	∅ 7	
191020080	∅ 8	
191020090	∅ 9	
191020100	∅ 10	
191020110	∅ 11	
191020120	∅ 12	
191120001		∅ 0.125-0.5
191120013-in		∅ 0.125
191120019-in		∅ 0.188
191120025-in		∅ 0.25
191120031-in		∅ 0.313
191120038-in		∅ 0.375
191120044-in		∅ 0.438
191120050-in		∅ 0.5

Collets DIN 6499D (ER/ESX) - sealed, for IC

Collets DIN 6499D (ER/ESX) - sealed, for IC



ER 25	mm	inch
191025000	ø 4-16	
191025030	ø 3	
191025040	ø 4	
191025050	ø 5	
191025060	ø 6	
191025070	ø 7	
191025080	ø 8	
191025090	ø 9	
191025100	ø 10	
191025110	ø 11	
191025120	ø 12	
191025130	ø 13	
191025140	ø 14	
191025150	ø 15	
191025160	ø 16	
191125001		ø 0.25-0.625
191125025-in		ø 0.25
191125031-in		ø 0.313
191125038-in		ø 0.375
191125044-in		ø 0.438
191125050-in		ø 0.5
191125056-in		ø 0.563
191125063-in		ø 0.625



ER 40	mm	inch
191040060	ø 6	
191040080	ø 8	
191040100	ø 10	
191040120	ø 12	
191040140	ø 14	
191040160	ø 16	
191040180	ø 18	
191040200	ø 20	
191040220	ø 22	
191040250	ø 25	
191140025-in		ø 0.25
191140031-in		ø 0.313
191140038-in		ø 0.375
191140044-in		ø 0.438
191140050-in		ø 0.5
191140056-in		ø 0.563
191140063-in		ø 0.625
191140069-in		ø 0.688
191140075-in		ø 0.75
191140088-in		ø 0.875
191140100-in		ø 1



ER 32	mm	inch
191032000	ø 4-20	
191032030	ø 3	
191032040	ø 4	
191032050	ø 5	
191032060	ø 6	
191032070	ø 7	
191032080	ø 8	
191032090	ø 9	
191032100	ø 10	
191032110	ø 11	
191032120	ø 12	
191032130	ø 13	
191032140	ø 14	
191032150	ø 15	
191032160	ø 16	
191032170	ø 17	
191032180	ø 18	
191032190	ø 19	
191032200	ø 20	
191132001		ø 0.25-0.75
191132025-in		ø 0.25
191132031-in		ø 0.313
191132038-in		ø 0.375
191132044-in		ø 0.438
191132050-in		ø 0.5
191132056-in		ø 0.563
191132063-in		ø 0.625
191132069-in		ø 0.688
191132075-in		ø 0.75



Quality without compromise.

All manufacturing steps are based on highest precision.

According to our own device that for the manufacture of high precision tooling systems high precision machine tools are essential we only use the latest machine tool technology to manufacture our parts.

At WTO not only the final products but also all manufacturing steps are checked and documented. All our products are measured on high precision 3D-coordinate-measuring machines.

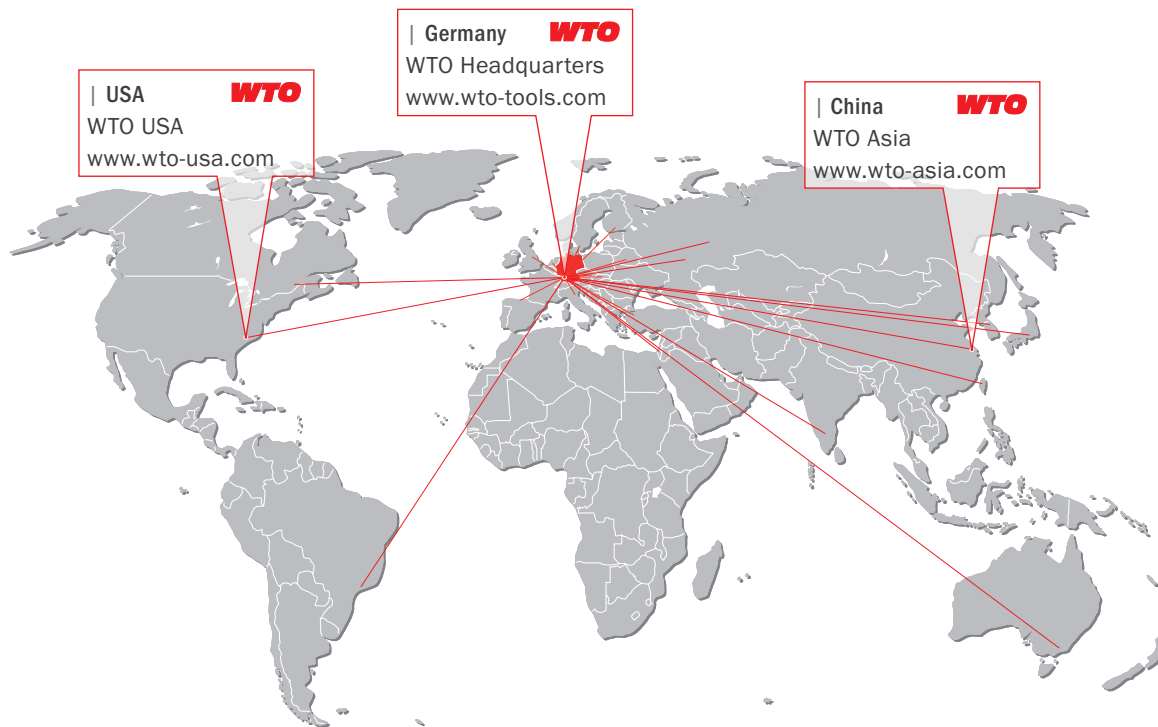

| USA **WTO**
WTO USA
www.wto-usa.com

| Germany **WTO**
WTO Headquarters
www.wto-tools.com

| China **WTO**
WTO Asia
www.wto-asia.com

WTO Werkzeug-
Einrichtungen GmbH
Auf der oberen Au 45
77797 Ohlsbach
Germany

WTO Inc.
13900-F South Lakes Dr.
Charlotte, NC 28273
USA

WTO Asia
Room 109-110, Building 2
No. 228 Banting Road
Jiuting Town,
Songjiang District
201615 Shanghai
China

Our distribution partners. Competence right there.

| Australia
Dimac Tooling Ltd.
sales@dimac.com.au

| Finland
Suomen Terätuonti Oy
myynti@stt.as

| Korea
WTO Office Korea
is.chon@wto-korea.com

| Slovakia
ALBA precision s.r.o.
albaprecision@albaprecision.sk

| Belarus
LLC "PMI Engineering"
tool@pmi.by

| France
Philippe Tagliafero
pta@wto.de

| Mexico
Workholding Engineering De México
info@wem.com.mx

| Spain
ITALMATIC, S.A.
italmatic@italmatic.es

| Brazil
TF2
tfdois@tfdois.com.br

| Great Britain
Cutwel Ltd.
sales@cutwel.net

| Netherlands
Toologic BeNeLux B.V.
info@toologic-benelux.nl

| Sweden
Bonhron & Ewing AB
info@bonhron-ewing.se

| Canada
Mittmann Industrial Inc.
info@mittmann.com

| India
Ulhas Patil
u.patil@wto-asia.com

| Norway
Helge Karlsen Verktøy og Maskin AS
hkvm@hkvm.no

| Switzerland
Utilis AG
info@utilis.com

| China
Shanghai Gangde
wtocando@yahoo.com

| Israel
E.Y.A.R. Ltd.
boris@eyar.co.il

| Poland
ARCO Andrzej Rudenko
info@arcotools.pl

| Taiwan
Kaiko Co., Ltd.
info@kaiko.com.tw

| Czech Republic
ALBA precision, spol. s.r.o.
info@albaprecision.cz

| Italy
Prymark srl
commerciale@prymark.it

| Romania
SC Elif Trading SRL
bulent.ozkan@eliftrading.com

| Turkey
MYK CNC MAKINA SAN. VE
huseyin.tatidil@mykcnc.com.tr

| Denmark
Tool-part
cj@tool-part.dk

| Japan
NK Works Co. Ltd.
k_samba@nk-works.co.jp

| Russia
WTO Office Russia
office@wto-russia.com

| Ukraine
„LLC“ SPA Stankopromimport
info@phoenix-ua.com